

- Programmable Look-Ahead Up/Down Binary Counters
- Fully Synchronous Operation for Counting and Programming
- Internal Look-Ahead for Fast Counting
- Carry Output for n-Bit Cascading
- Fully Independent Clock Circuit

SN54LS169B, SN54S169 . . . J OR W PACKAGE  
SN74LS169B, SN74S169 . . . D OR N PACKAGE

(TOP VIEW)

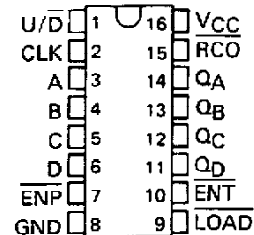

SN54LS169B, SN54S169 . . . FK PACKAGE

(TOP VIEW)

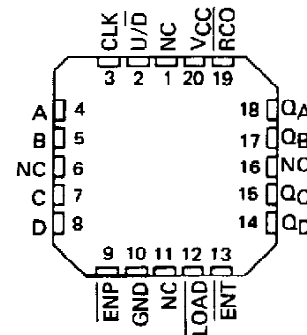

NC—No internal connection

### description

These synchronous presettable counters feature an internal carry look-ahead for cascading in high speed counting applications. The 'LS169B and 'S169 are 4-bit binary counters. Synchronous operation is provided by having all flip-flops clocked simultaneously so that the outputs change coincident with each other when so instructed by the count-enable inputs and internal gating. This mode of operation helps eliminate the output counting spikes that are normally associated with asynchronous (ripple-clock) counters. A buffered clock input triggers the four master-slave flip-flops on the rising (positive-going) edge of the clock waveform.

These counters are fully programmable; that is the outputs may each be preset to either level. The load input circuitry allows loading with the carry-enable output of cascaded counters. As loading is synchronous, setting up a low level at the load input disables the counter and causes the outputs to agree with the data inputs after the next clock pulse.

The carry look-ahead circuitry provides for cascading counters for n-bit synchronous applications without additional gating. Instrumental in accomplishing this function are two count-enable inputs and a carry output. Both count enable inputs (ENP, ENT) must be low to count. The direction of the count is determined by the level of the up/down input. When the input is high, the counter counts up; when low, it counts down. Input ENT is fed forward to enable the carry output. The carry output thus enabled will produce a low-level output pulse with a duration approximately equal to the high portion of the  $Q_A$  output when counting up and approximately equal to the low portion of the  $Q_A$  output when counting down. This low-level overflow carry pulse can be used to enable successive cascaded stages. Transitions at the ENP or ENT inputs are allowed regardless of the level of the clock input. All inputs are diode-clamped to minimize transmission-line effects, thereby simplifying system design.

These counters feature a fully independent clock circuit. Changes at control inputs ( $\overline{\text{ENP}}$ ,  $\overline{\text{ENT}}$ ,  $\overline{\text{LOAD}}$ ,  $\overline{\text{U/D}}$ ) that will modify the operating mode have no effect until clocking occurs. The function of the counter (whether enabled, disabled, loading, or counting) will be dictated solely by the conditions meeting the stable setup and hold times.

TYPE	TYPICAL MAXIMUM CLOCK FREQUENCY		TYPICAL POWER DISSIPATION
	COUNTING UP	COUNTING DOWN	
'LS169B	35MHz	35MHz	100mW
'S169	70MHz	55MHz	500mW

PRODUCTION DATA documents contain information current as of publication date. Products conform to specifications per the terms of Texas Instruments standard warranty. Production processing does not necessarily include testing of all parameters.

TEXAS  
INSTRUMENTS

POST OFFICE BOX 655013

DALLAS, TEXAS 75265

**SN54LS169B, SN54S169,  
SN74LS169B, SN74S169  
SYNCHRONOUS 4-BIT UP/DOWN BINARY COUNTERS**

logic symbol†

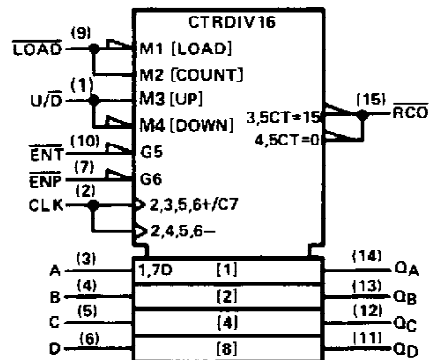

†This symbol is in accordance with ANSI/IEEE Std. 91-1984 and IEC Publication 617-12. Pin numbers shown are for D, J, N, and W packages.

**SN54LS169B, SN74LS169B**  
**SYNCHRONOUS 4-BIT UP/DOWN BINARY COUNTERS**

logic diagram (positive logic)

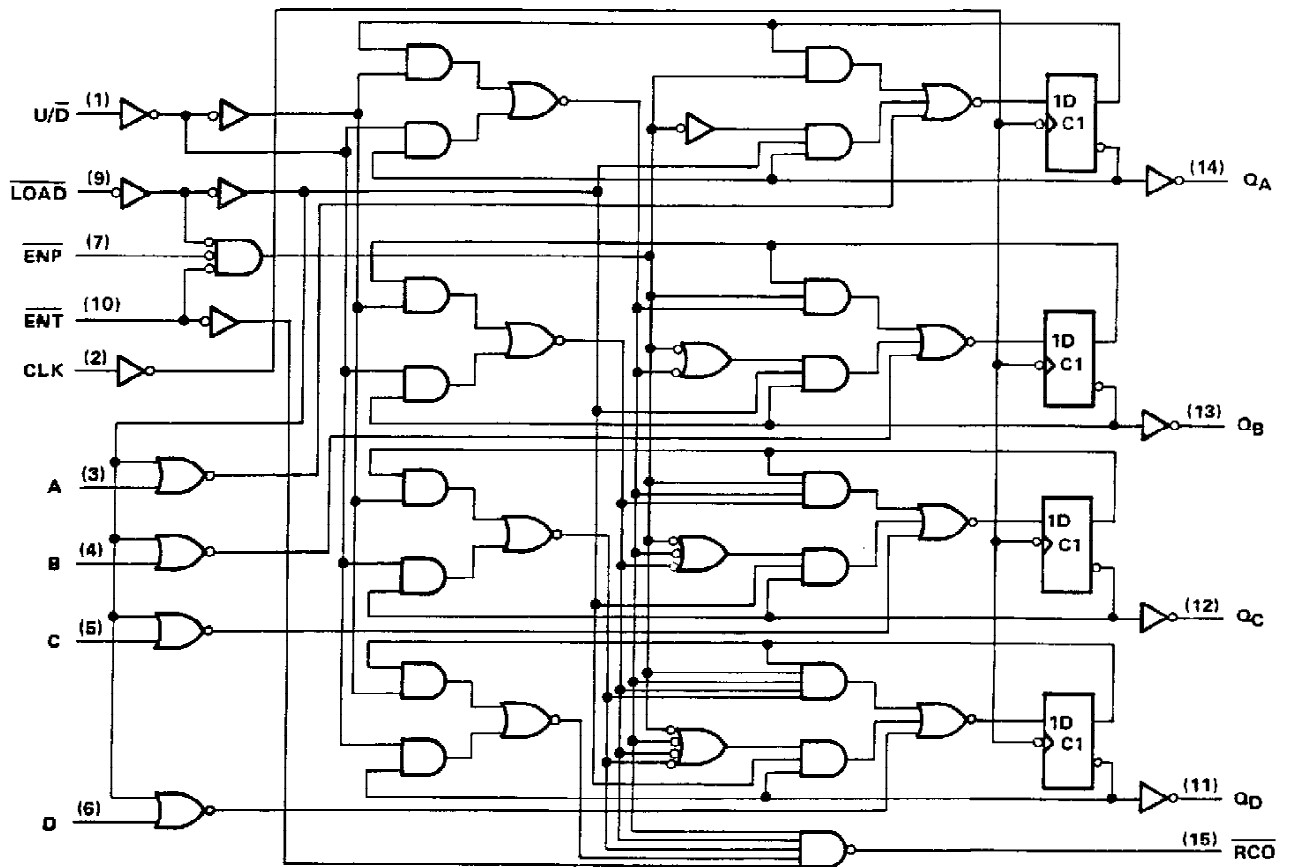

Pin numbers shown are for D, J, N, and W packages.

# SN54S169, SN74S169 SYNCHRONOUS 4-BIT UP/DOWN BINARY COUNTERS

logic diagram (positive logic)

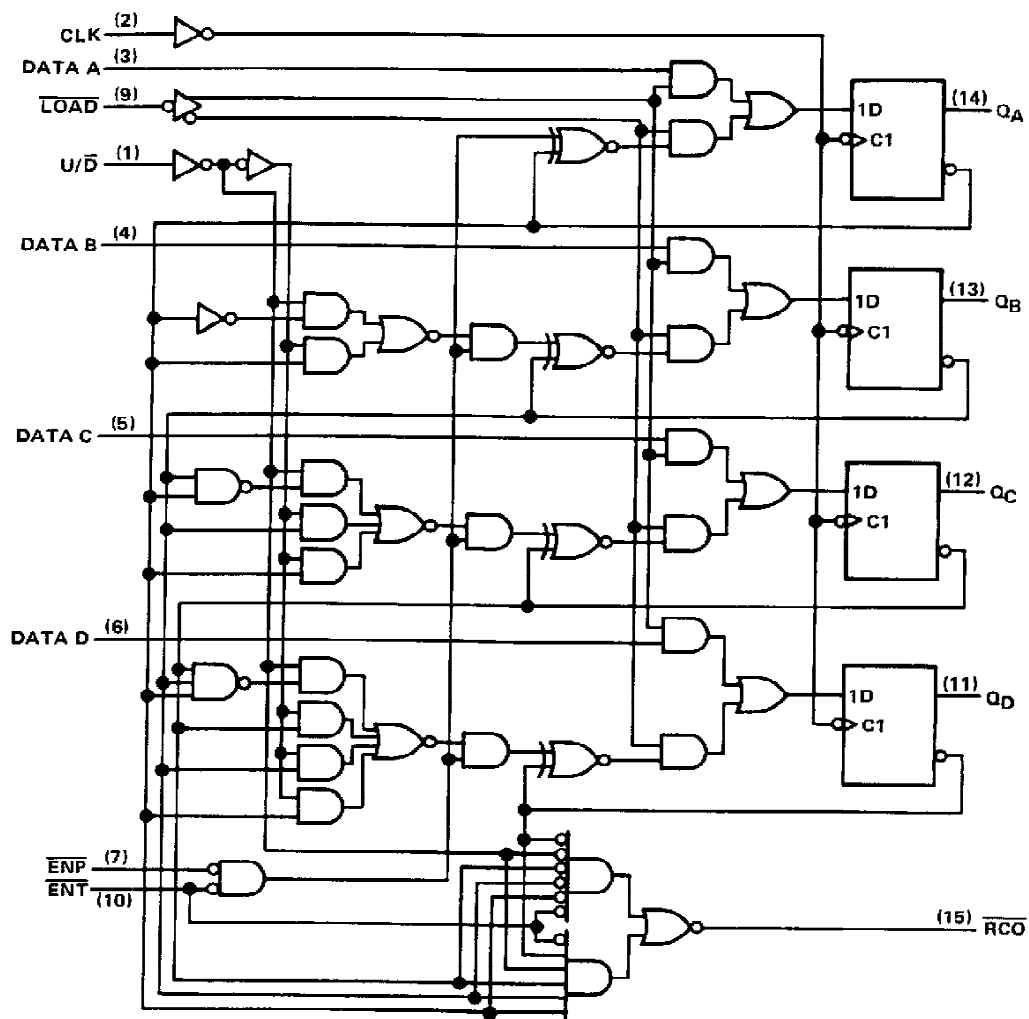

Pin numbers shown are for D, J, N, and W packages.

TEXAS  
INSTRUMENTS

POST OFFICE BOX 655012 • DALLAS, TEXAS 75265

**SN54LS169B, SN54S169, SN74LS169B, SN74S169  
SYNCHRONOUS 4-BIT UP/DOWN BINARY COUNTERS**

**typical load, count, and inhibit sequences**

Illustrated below is the following sequence:

1. Load (preset) to binary thirteen
2. Count up to fourteen, fifteen (maximum), zero, one, and two
3. Inhibit
4. Count down to one, zero (minimum), fifteen, fourteen, and thirteen

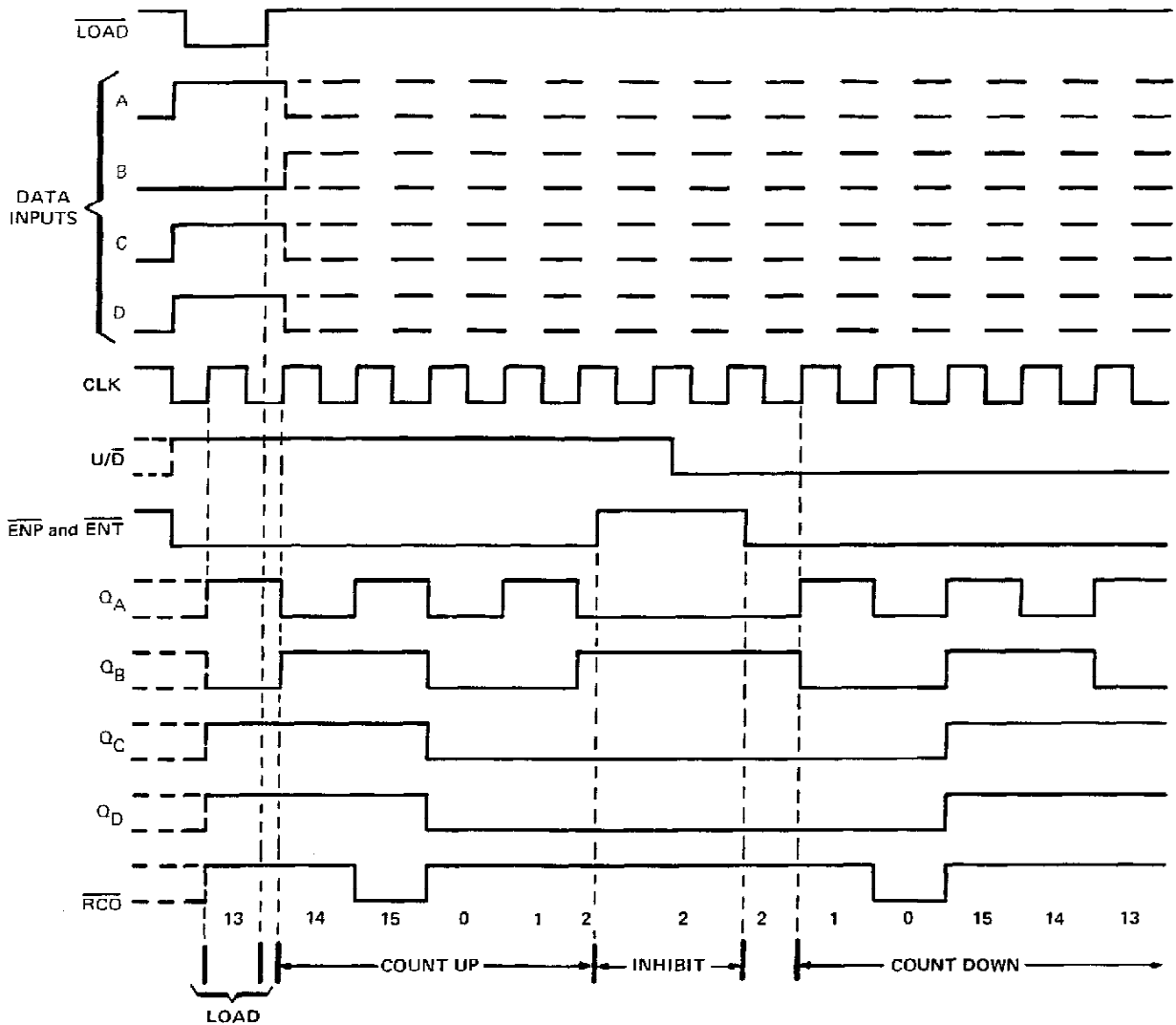

# SN54LS169B, SN74LS179B SYNCHRONOUS 4-BIT UP/DOWN BINARY COUNTERS

## schematics of inputs and outputs

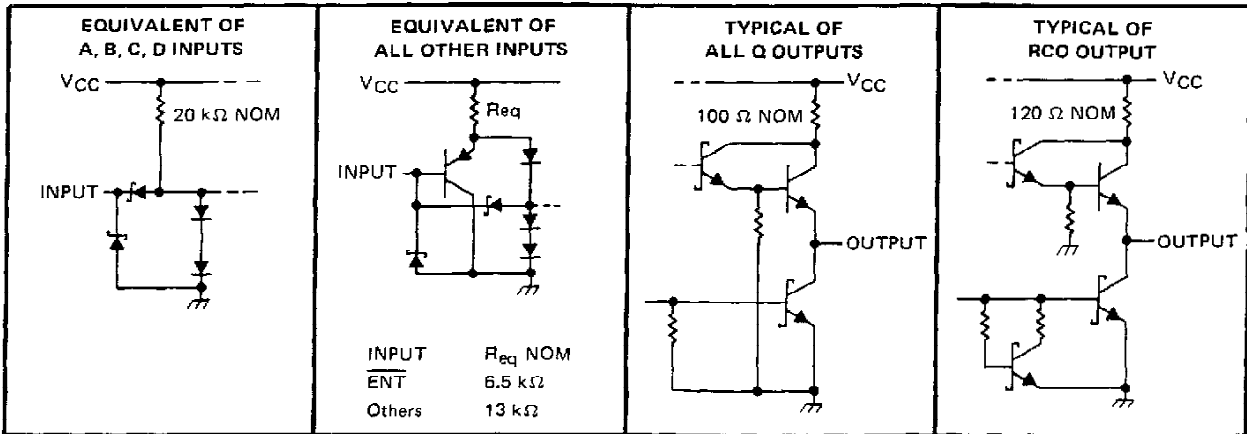

## absolute maximum ratings over operating free-air temperature range (unless otherwise noted)

Supply voltage, $V_{CC}$ (see Note 1)	.....	7 V
Input voltage	.....	7 V
Operating free-air temperature range: SN54LS169B	.....	-55°C to 125°C
SN74LS169B	.....	0°C to 70°C
Storage temperature range	.....	-65°C to 150°C

NOTE 1: Voltage values are with respect to network ground terminal.

## recommended operating conditions

		SN54LS169B			SN74LS169B			UNIT
		MIN	NOM	MAX	MIN	NOM	MAX	
$V_{CC}$	Supply voltage	4.5	5	5.5	4.75	5	5.25	V
$V_{IH}$	High-level input voltage	2			2			V
$V_{IL}$	Low-level input voltage	0.7			0.8			V
$I_{OH}$	High-level output current	RCO		-0.4	-0.4		mA	
		Any Q		-1.2	-1.2		mA	
$I_{OL}$	Low-level output current	RCO		4	8		mA	
		Any Q		12	24		mA	
$f_{clock}$	Clock frequency	0	20	0	20		MHz	
$t_{w(clock)}$	Width of clock pulse (high or low) (see Figure 1)	25			25			ns
$t_{su}$	Setup time, (see Figure 1)	Data inputs A, B, C, D		30			ns	
		ENT or ENT		30				
		Load		35				
		U/D		35				
$t_h$	Hold time at any input with respect to clock (see Figure 1)	0			0			ns
$T_A$	Operating free-air temperature	-55		125	0		70	°C



POST OFFICE BOX 655012 • DALLAS, TEXAS 75265

## SN54LS169B, SN74LS169B SYNCHRONOUS 4-BIT UP/DOWN BINARY COUNTERS

electrical characteristics over recommended operating free-air temperature range (unless otherwise noted)

PARAMETER	TEST CONDITIONS†	SN54LS169B		SN74LS169B		UNIT		
		MIN	TYP‡	MAX	MIN		TYP‡	MAX
$V_{IK}$	$V_{CC} = \text{MIN.}$ , $I_I = -18 \text{ mA}$			-1.5		V		
$V_{OH}$	$V_{CC} = \text{MIN.}$ , $V_{IH} = 2 \text{ V.}$ $V_{IL} = \text{MAX.}$	$\overline{RCO}$	$I_{OH} = -0.4 \text{ mA}$	2.5	3.4	2.7	3.4	V
		Any Q	$I_{OH} = -1.2 \text{ mA}$	2.4	3.2	2.4	3.2	
$V_{OL}$	$V_{CC} = \text{MIN.}$ , $V_{IH} = 2 \text{ V.}$ $V_{IL} = \text{MAX.}$	$\overline{RCO}$	$I_{OH} = 4 \text{ mA}$	0.25	0.4	0.25	0.4	V
			$I_{OL} = 8 \text{ mA}$			0.35	0.5	
		Any Q	$I_{OL} = 12 \text{ mA}$	0.25	0.4	0.25	0.4	
			$I_{OL} = 24 \text{ mA}$			0.35	0.5	
$I_I$	$V_{CC} = \text{MAX.}$ , $V_I = 7 \text{ V}$			0.1		0.1	mA	
$I_{IH}$	$V_{CC} = \text{MAX.}$ , $V_I = 2.7 \text{ V}$			20		20	$\mu\text{A}$	
$I_{IL}$	$V_{CC} = \text{MAX.}$ , $V_I = 0.4 \text{ V}$	U/D, LOAD, $\overline{ENP}$ , CLK		-0.2		-0.2		mA
		All other inputs		-0.4		-0.4		
$I_{OS}\S$	$V_{CC} = \text{MAX.}$ , $V_O = 0 \text{ V}$	$\overline{RCO}$		-20	-100	-20	-100	mA
		Any Q		-30	-130	-30	-130	
$I_{CC}$	$V_{CC} = \text{MAX.}$ , See Note 2			28	45	28	45	mA

† For conditions shown as MIN or MAX, use the appropriate value specified under recommended operating conditions.

‡ All typical values are at  $V_{CC} = 5 \text{ V}$ ,  $T_A = 25^\circ \text{C}$ .

§ Not more than one output should be shorted at a time, and duration of the short-circuit should not exceed one second.

NOTE 2:  $I_{CC}$  is measured after applying a momentary 4.5 V, then ground, to the clock input with all other inputs grounded and the outputs open.

switching characteristics,  $V_{CC} = 5 \text{ V}$ ,  $T_A = 25^\circ \text{C}$  (see note 3)

PARAMETER¶	FROM (INPUT)	TO (OUTPUT)	TEST CONDITIONS	LS169B			UNIT
				MIN	TYP	MAX	
$f_{\text{max}}$				20	35		MHz
$t_{PLH}$	CLK	$\overline{RCO}$	$R_L = 2 \text{ k}\Omega$ , $C_L = 15 \text{ pF}$	26	40		ns
$t_{PHL}$				17	25		
$t_{PLH}$	$\overline{ENT}$	$\overline{RCO}$		15	25		ns
$t_{PHL}$				11	20		
$t_{PLH}$	U/D	$\overline{RCO}$		23	35		ns
$t_{PHL}$				15	25		
$t_{PLH}$	CLK	Any Q	$R_L = 667 \Omega$ , $C_L = 45 \text{ pF}$	16	25		ns
$t_{PHL}$				17	25		

¶ Propagation delay time from up/down to ripple carry must be measured with the counter at either a minimum or a maximum count. As the logic level of the up/down input is changed, the ripple carry output will follow. If the count is minimum (0), the ripple carry output transition will be in phase. If the count is maximum (15), the ripple carry output will be out of phase.

NOTE 3: Load circuits and voltage waveforms are shown in Section 1.

  
**TEXAS**  
**INSTRUMENTS**

POST OFFICE BOX 655012 • DALLAS, TEXAS 75265

# SN54S169, SN74S169 SYNCHRONOUS 4-BIT UP/DOWN BINARY COUNTERS

## schematics of inputs and outputs

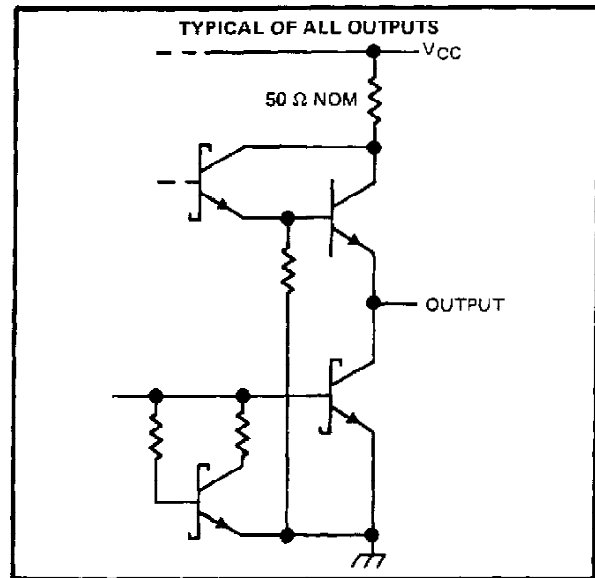
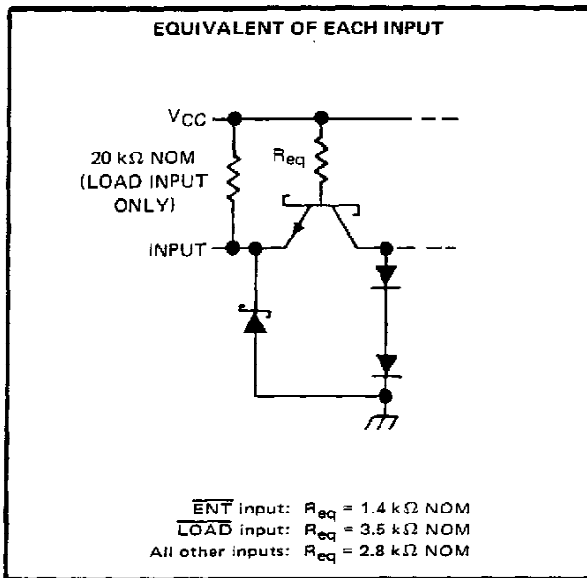

## absolute maximum ratings over operating free-air temperature range (unless otherwise noted)

Supply voltage, $V_{CC}$ (See Note 4) .....	7 V
Input voltage .....	5.5 V
Intermitter voltage (See Note 5) .....	5.5 V
Operating free-air temperature range: SN54S169 (see Note 6) .....	-55°C to 125°C
SN74S169 .....	0°C to 70°C
Storage temperature range .....	-65°C to 150°C

## recommended operating conditions

	SN54S169			SN74S169			UNIT
	MIN	NOM	MAX	MIN	NOM	MAX	
Supply voltage, $V_{CC}$	4.5	5	5.5	4.75	5	5.25	V
High-level output current, $I_{OH}$			-1			-1	mA
Low-level output current, $I_{OL}$			20			20	mA
Clock frequency, $f_{clock}$	0		40	0		40	MHz
Width of clock pulse, $t_w(\text{clock})$ (high or low) (see Figure 1)	10			10			ns
Setup time, $t_{SU}$ (see Figure 11)	Data inputs A, B, C, D	4		4			ns
	$\overline{ENP}$ or $\overline{ENT}$	14		14			
	Load	9		6			
	$U/\overline{D}$	20		20			
Hold time at any input with respect to clock, $t_H$ (see Figure 11)	1			1			ns
Operating free-air temperature, $T_A$ (See Note 6)	-55		125	0		70	°C

- NOTES: 4. Voltage values, except intermitter voltage, are with respect to network ground terminal.  
 5. This is the voltage between two emitters of a multiple-emitter transistor. For these circuits, this rating applies between the count enable inputs  $\overline{ENP}$  and  $\overline{ENT}$ .  
 6. A SN54S169 in the W package operating at free-air temperatures above 91°C requires a heat sink that provides a thermal resistance from case to free-air,  $R_{\theta CA}$ , of not more than 26°C/W.

## SN54S169, SN74S169 SYNCHRONOUS 4-BIT UP/DOWN BINARY COUNTERS

electrical characteristics over recommended operating free-air temperature range (unless otherwise noted)

PARAMETER	TEST CONDITIONS†	SN54S169			SN74S169			UNIT	
		MIN	TYP‡	MAX	MIN	TYP‡	MAX		
V <sub>IH</sub> High-level input voltage		2			2			V	
V <sub>IL</sub> Low-level input voltage				0.8			0.8	V	
V <sub>IK</sub> Input clamp voltage	V <sub>CC</sub> = MIN, I <sub>I</sub> = -18 mA			-1.2			-1.2	V	
V <sub>OH</sub> High-level output voltage	V <sub>CC</sub> = MIN, V <sub>IH</sub> = 2 V, V <sub>IL</sub> = 0.8 V, I <sub>OH</sub> = -1 mA	2.5	3.4		2.7	3.4		V	
V <sub>OL</sub> Low-level output voltage	V <sub>CC</sub> = MIN, V <sub>IH</sub> = 2 V, V <sub>IL</sub> = 0.8 V, I <sub>OL</sub> = 20 mA			0.5			0.5	V	
I <sub>I</sub> Input current at maximum input voltage	V <sub>CC</sub> = MAX, V <sub>I</sub> = 5.5 V			1			1	mA	
I <sub>IH</sub> High-level input current	ENT			100			100	μA	
	Load	V <sub>CC</sub> = MAX, V <sub>I</sub> = 2.7 V		-10		-200	-10		-200
	Other inputs				50		50		
I <sub>IL</sub> Low-level input current	ENT	V <sub>CC</sub> = MAX, V <sub>I</sub> = 0.5 V				-4		-4	
	Other inputs				-2		-2		
I <sub>OS</sub> Short-circuit output current‡	V <sub>CC</sub> = MAX,	-40		-100	-40		-100	mA	
I <sub>CC</sub> Supply current	V <sub>CC</sub> = MAX. See Note 2		100	160		100	160	mA	

† For conditions shown as MIN or MAX, use the appropriate value specified under recommended operating conditions.

‡ All typical values are at V<sub>CC</sub> = 5 V, T<sub>A</sub> = 25°C.

§ Not more than one output should be shorted at a time, and duration of the short-circuit should not exceed one second.

NOTE 2: I<sub>CC</sub> is measured after applying a momentary 4.5 V, then ground, to the clock input with all other inputs grounded and the outputs open.

switching characteristics, V<sub>CC</sub> = 5 V, T<sub>A</sub> = 25°C

PARAMETER¶	FROM (INPUT)	TO (OUTPUT)	TEST CONDITIONS	U/D = HIGH			U/D = LOW			UNIT
				MIN	TYP	MAX	MIN	TYP	MAX	
f <sub>max</sub>			C <sub>L</sub> = 15 pF, R <sub>L</sub> = 280 Ω. See Figures 2 and 3 and Note 3	40	70		40	55		MHz
t <sub>PLH</sub>	CLK	RCO		14	21		14	21		ns
t <sub>PHL</sub>		RCO		20	28		20	28		
t <sub>PLH</sub>	CLK	Any Q		8	15		8	15		ns
t <sub>PHL</sub>		Any Q		11	15		11	15		
t <sub>PLH</sub>	ENT	RCO		7.5	11		6	12		ns
t <sub>PHL</sub>		RCO		15	22		15	25		
t <sub>PLH</sub> ⊙	U/D	RCO		9	15		8	15		ns
t <sub>PHL</sub> ⊙				10	15		16	22		

¶ f<sub>max</sub> = maximum clock frequency

t<sub>PLH</sub> = propagation delay time, low-to-high-level output

t<sub>PHL</sub> = propagation delay time, high-to-low-level output

Propagation delay time from up/down to ripple carry must be measured with the counter at either a minimum or a maximum count. As the logic level of the up/down input is changed, the ripple carry output will follow. If the count is minimum (0), the ripple carry output transition will be in phase. If the count is maximum (15 for 'S169), the ripple carry output will be out of phase.

NOTE 3: Load circuits and voltage waveforms are shown in Section 1.

  
**TEXAS  
INSTRUMENTS**

POST OFFICE BOX 655013 • DALLAS, TEXAS 75265

**SN54LS169B, SN54S168,  
SN74LS169B, SN74S169  
SYNCHRONOUS 4-BIT UP/DOWN BINARY COUNTERS**

**PARAMETER MEASUREMENT INFORMATION**

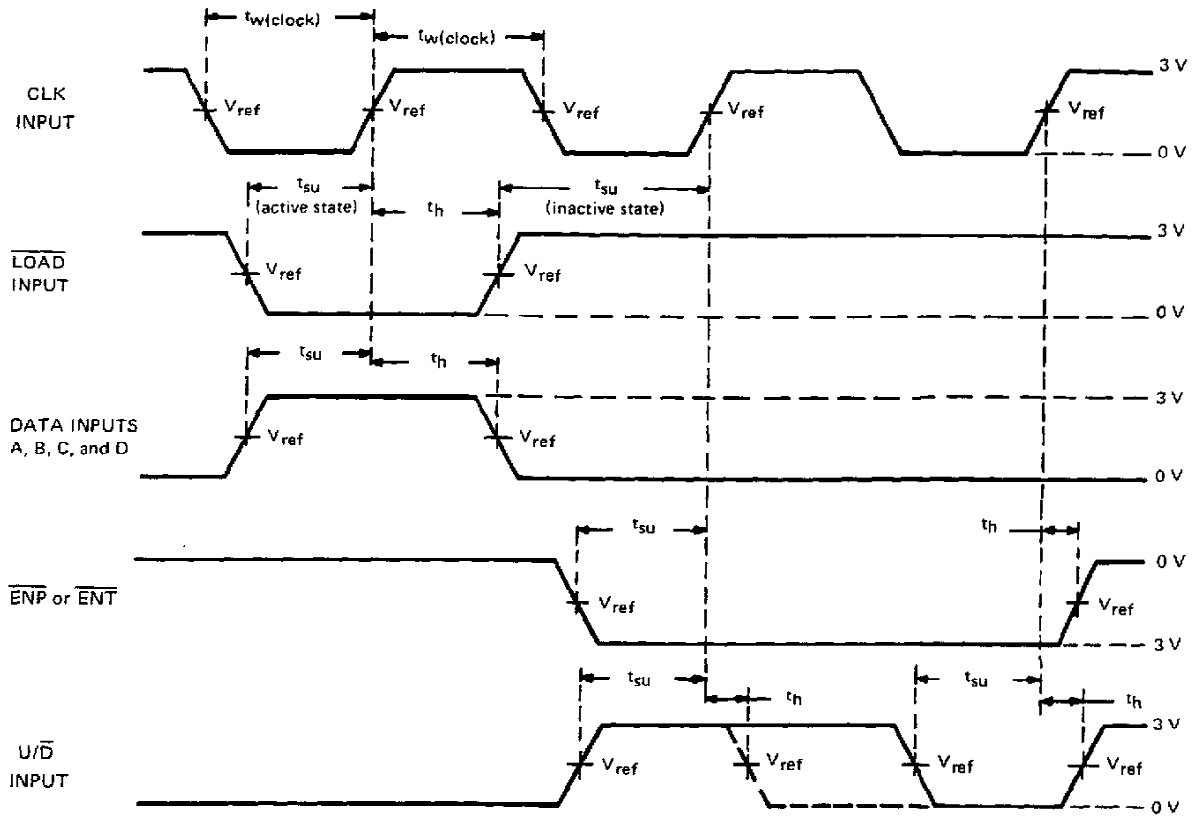

**VOLTAGE WAVEFORMS**

- NOTES: A. The input pulses are supplied by a generator having the following characteristics: PRR  $\leq$  1 MHz, duty cycle  $\leq$  50%,  $Z_{out} \approx 50 \Omega$ ; for 'LS169B,  $t_r \leq 15$  ns;  $t_f \leq 6$  ns, and for 'S169,  $t_r \leq 2.5$  ns,  $t_f \leq 2.5$  ns.  
B. For 'LS169B,  $V_{ref} = 1.3$  V; for 'S168 and 'S169,  $V_{ref} = 1.5$  V.

**FIGURE 1—PULSE WIDTHS, SETUP TIMES, HOLD TIMES**

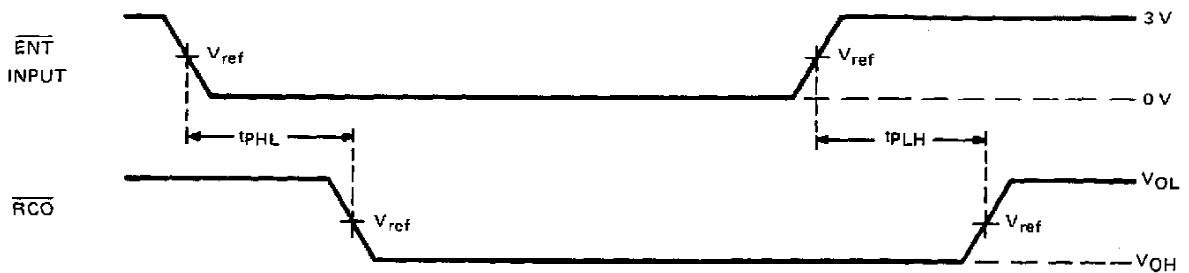

**VOLTAGE WAVEFORMS**

- NOTES: A. The input pulses are supplied by a generator having the following characteristics: PRR  $\leq$  1 MHz, duty cycle  $\leq$  50%,  $Z_{out} \approx 50 \Omega$ ; for 'LS169B,  $t_r \leq 15$  ns,  $t_f \leq 5$  ns; and for 'S169,  $t_r \leq 2.5$  ns,  $t_f \leq 2.5$  ns.  
B.  $t_{PLH}$  and  $t_{PHL}$  from enable T input to ripple carry output assume that the counter is at the maximum count, all Q outputs high.  
C. For 'LS169B,  $V_{ref} = 1.3$  V; for 'S169,  $V_{ref} = 1.5$  V.  
D. Propagation delay time from up/down to ripple carry must be measured with the counter at either a minimum or a maximum count. As the logic level of the up/down input is changed, the ripple carry output will follow. If the count is minimum (0) the ripple carry output transition will be in phase. If the count is maximum (15), the ripple carry output will be out of phase.

**FIGURE 2—PROPAGATION DELAY TIMES TO CARRY OUTPUT**



**SN54LS169B, SN54S169,  
SN74LS169B, SN74S169**  
**SYNCHRONOUS 4-BIT UP/DOWN BINARY COUNTERS**

**PARAMETER MEASUREMENT INFORMATION**

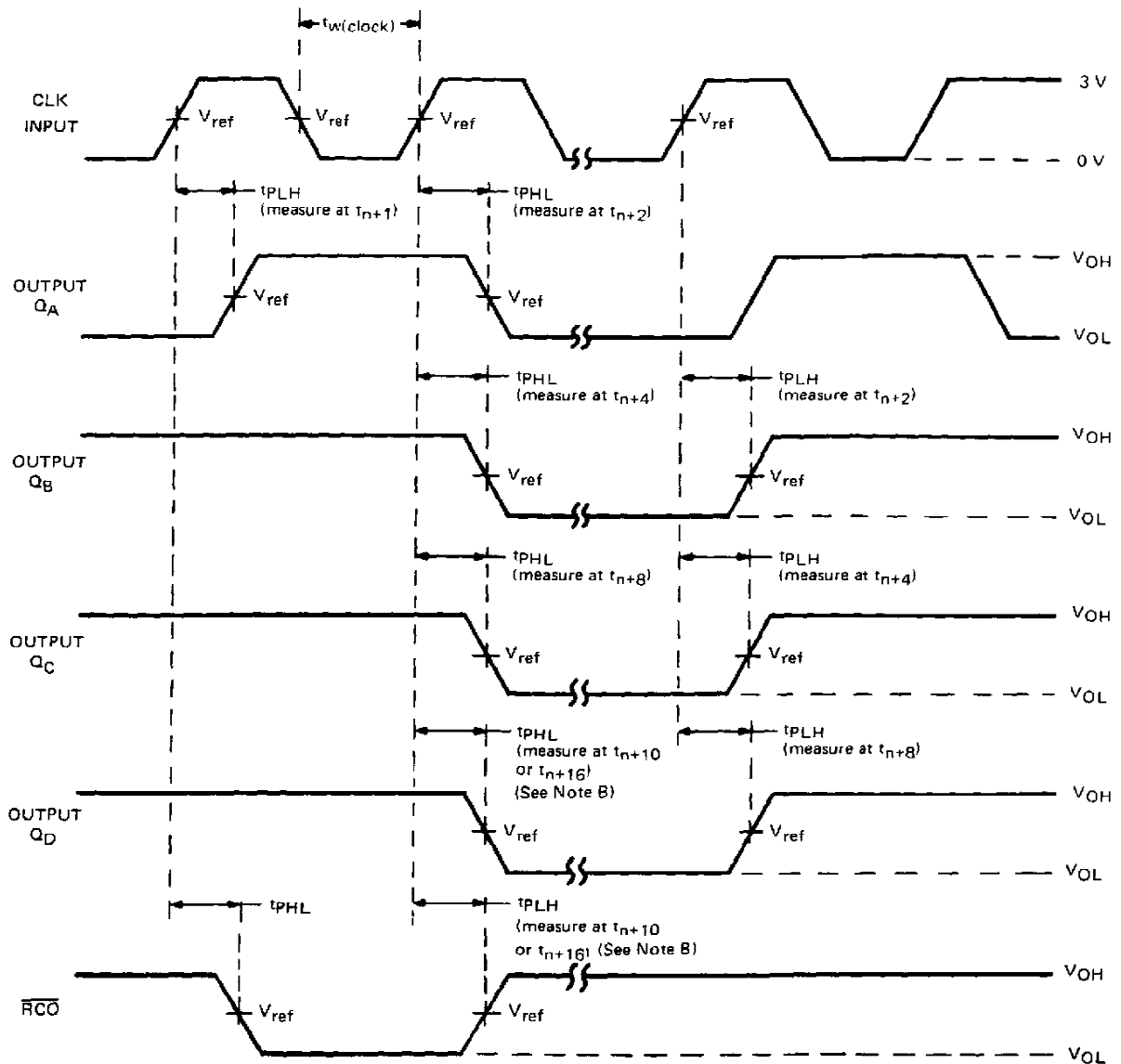

**UP-COUNT VOLTAGE WAVEFORMS**

- NOTES: A. The input pulses are supplied by a generator having the following characteristics:  $PRR \leq 1 \text{ MHz}$ , duty cycle  $\leq 50\%$ ,  $Z_{out} \approx 50 \Omega$ ; for 'LS169B,  $t_r \leq 15 \text{ ns}$ ,  $t_f \leq 6 \text{ ns}$ , and 'S169,  $t_r \leq 2.5 \text{ ns}$ ,  $t_f \leq 2.5 \text{ ns}$ . Vary PRR to measure  $f_{max}$ .  
 B. Outputs  $Q_D$  and carry are tested at  $t_{n+16}$ , where  $t_n$  is the bit-time when all outputs are low.  
 C. For 'LS169B,  $V_{ref} = 1.3 \text{ V}$ ; for 'S169,  $V_{ref} = 1.5 \text{ V}$ .

**FIGURE 3—PROPAGATION DELAY TIMES FROM CLOCK**

**TEXAS  
INSTRUMENTS**

POST OFFICE BOX 656012 • DALLAS, TEXAS 75265

## IMPORTANT NOTICE

Texas Instruments (TI) reserves the right to make changes to its products or to discontinue any semiconductor product or service without notice, and advises its customers to obtain the latest version of relevant information to verify, before placing orders, that the information being relied on is current.

TI warrants performance of its semiconductor products and related software to the specifications applicable at the time of sale in accordance with TI's standard warranty. Testing and other quality control techniques are utilized to the extent TI deems necessary to support this warranty. Specific testing of all parameters of each device is not necessarily performed, except those mandated by government requirements.

Certain applications using semiconductor products may involve potential risks of death, personal injury, or severe property or environmental damage ("Critical Applications").

TI SEMICONDUCTOR PRODUCTS ARE NOT DESIGNED, INTENDED, AUTHORIZED, OR WARRANTED TO BE SUITABLE FOR USE IN LIFE-SUPPORT APPLICATIONS, DEVICES OR SYSTEMS OR OTHER CRITICAL APPLICATIONS.

Inclusion of TI products in such applications is understood to be fully at the risk of the customer. Use of TI products in such applications requires the written approval of an appropriate TI officer. Questions concerning potential risk applications should be directed to TI through a local SC sales office.

In order to minimize risks associated with the customer's applications, adequate design and operating safeguards should be provided by the customer to minimize inherent or procedural hazards.

TI assumes no liability for applications assistance, customer product design, software performance, or infringement of patents or services described herein. Nor does TI warrant or represent that any license, either express or implied, is granted under any patent right, copyright, mask work right, or other intellectual property right of TI covering or relating to any combination, machine, or process in which such semiconductor products or services might be or are used.

## **IMPORTANT NOTICE**

Texas Instruments (TI) reserves the right to make changes to its products or to discontinue any semiconductor product or service without notice, and advises its customers to obtain the latest version of relevant information to verify, before placing orders, that the information being relied on is current.

TI warrants performance of its semiconductor products and related software to the specifications applicable at the time of sale in accordance with TI's standard warranty. Testing and other quality control techniques are utilized to the extent TI deems necessary to support this warranty. Specific testing of all parameters of each device is not necessarily performed, except those mandated by government requirements.

Certain applications using semiconductor products may involve potential risks of death, personal injury, or severe property or environmental damage ("Critical Applications").

**TI SEMICONDUCTOR PRODUCTS ARE NOT DESIGNED, INTENDED, AUTHORIZED, OR WARRANTED TO BE SUITABLE FOR USE IN LIFE-SUPPORT APPLICATIONS, DEVICES OR SYSTEMS OR OTHER CRITICAL APPLICATIONS.**

Inclusion of TI products in such applications is understood to be fully at the risk of the customer. Use of TI products in such applications requires the written approval of an appropriate TI officer. Questions concerning potential risk applications should be directed to TI through a local SC sales office.

In order to minimize risks associated with the customer's applications, adequate design and operating safeguards should be provided by the customer to minimize inherent or procedural hazards.

TI assumes no liability for applications assistance, customer product design, software performance, or infringement of patents or services described herein. Nor does TI warrant or represent that any license, either express or implied, is granted under any patent right, copyright, mask work right, or other intellectual property right of TI covering or relating to any combination, machine, or process in which such semiconductor products or services might be or are used.