

# SN74LS224A

## 16 × 4 SYNCHRONOUS FIRST-IN, FIRST-OUT MEMORY WITH 3-STATE OUTPUTS

SDLS023B – JANUARY 1991 – REVISED APRIL 1998

- Independent Synchronous Inputs and Outputs
- 16 Words by 4 Bits Each
- 3-State Outputs Drive Bus Lines Directly
- Data Rates up to 10 MHz
- Fall-Through Time 50 ns Typical
- Data Terminals Arranged for Printed Circuit Board Layout
- Expandable Using External Gating
- Packaged in Standard Plastic 300-mil DIPs

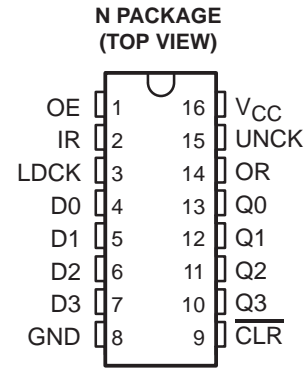

### description

The SN74LS224A 64-bit, low-power Schottky memory is organized as 16 words by 4 bits each. It can be expanded in multiples of  $15m + 1$  words or  $4n$  bits or both (where  $n$  is the number of packages in the vertical array and  $m$  is the number of packages in the horizontal array); however, some external gating is required. For longer words the input ready (IR) signals of the first-rank packages and output ready (OR) signals of the last-rank packages must be ANDed for proper synchronization.

A first-in, first-out (FIFO) memory is a storage device that allows data to be written to and read from its array at independent data rates. These FIFOs are designed to process data at rates up to 10 MHz in a bit-parallel format, word by word.

Data is written into memory on a low-to-high transition of load-clock (LDCK) and is read out on a low-to-high transition of unload-clock (UNCK). The memory is full when the number of words clocked in exceeds the number of words clocked out by 16. When the memory is full, LDCK signals have no effect on the data residing in memory. When the memory is empty, UNCK signals have no effect.

Status of the FIFO memory is monitored by the IR and OR flags that indicate not-full and not-empty conditions. IR is high only when the memory is not full and the LDCK is low. OR is high only when the memory is not empty and UNCK is high.

A low level on the clear ( $\overline{\text{CLR}}$ ) input resets the internal stack-control pointers and also sets IR high and OR low to indicate that old data remaining at the data outputs is invalid. Data outputs are noninverting with respect to the data inputs and are at high impedance when the output-enable (OE) input is low. OE does not affect the IR and OR outputs.

The SN74LS224A is characterized for operation from 0°C to 70°C.



Please be aware that an important notice concerning availability, standard warranty, and use in critical applications of Texas Instruments semiconductor products and disclaimers thereto appears at the end of this data sheet.

PRODUCTION DATA information is current as of publication date. Products conform to specifications per the terms of Texas Instruments standard warranty. Production processing does not necessarily include testing of all parameters.

**TEXAS  
INSTRUMENTS**

POST OFFICE BOX 655303 • DALLAS, TEXAS 75265

Copyright © 1998, Texas Instruments Incorporated

# SN74LS224A

## 16 × 4 SYNCHRONOUS FIRST-IN, FIRST-OUT MEMORY WITH 3-STATE OUTPUTS

SDLS023B – JANUARY 1991 – REVISED APRIL 1998

### logic symbol†

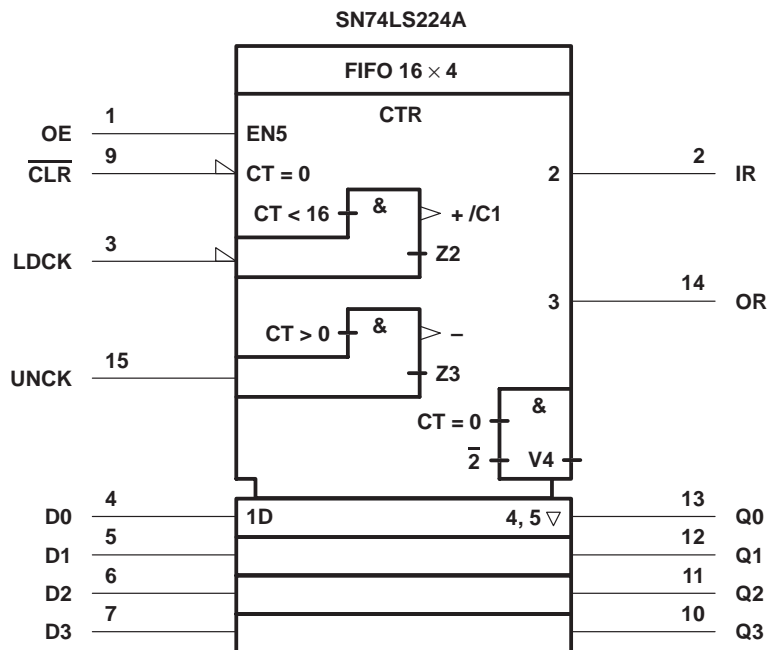

† This symbol is in accordance with ANSI/IEEE Standard 91-1984 and IEC Publication 617-12. This symbol is functionally accurate but does not show the details of implementation; for these, see the logic diagram. The symbol represents the memory as if it were controlled by a single counter whose content is the number of words stored at the time. Output data is invalid when the counter content (CT) is 0.

# SN74LS224A

## 16 × 4 SYNCHRONOUS FIRST-IN, FIRST-OUT MEMORY WITH 3-STATE OUTPUTS

SDLS023B – JANUARY 1991 – REVISED APRIL 1998

logic diagram (positive logic)

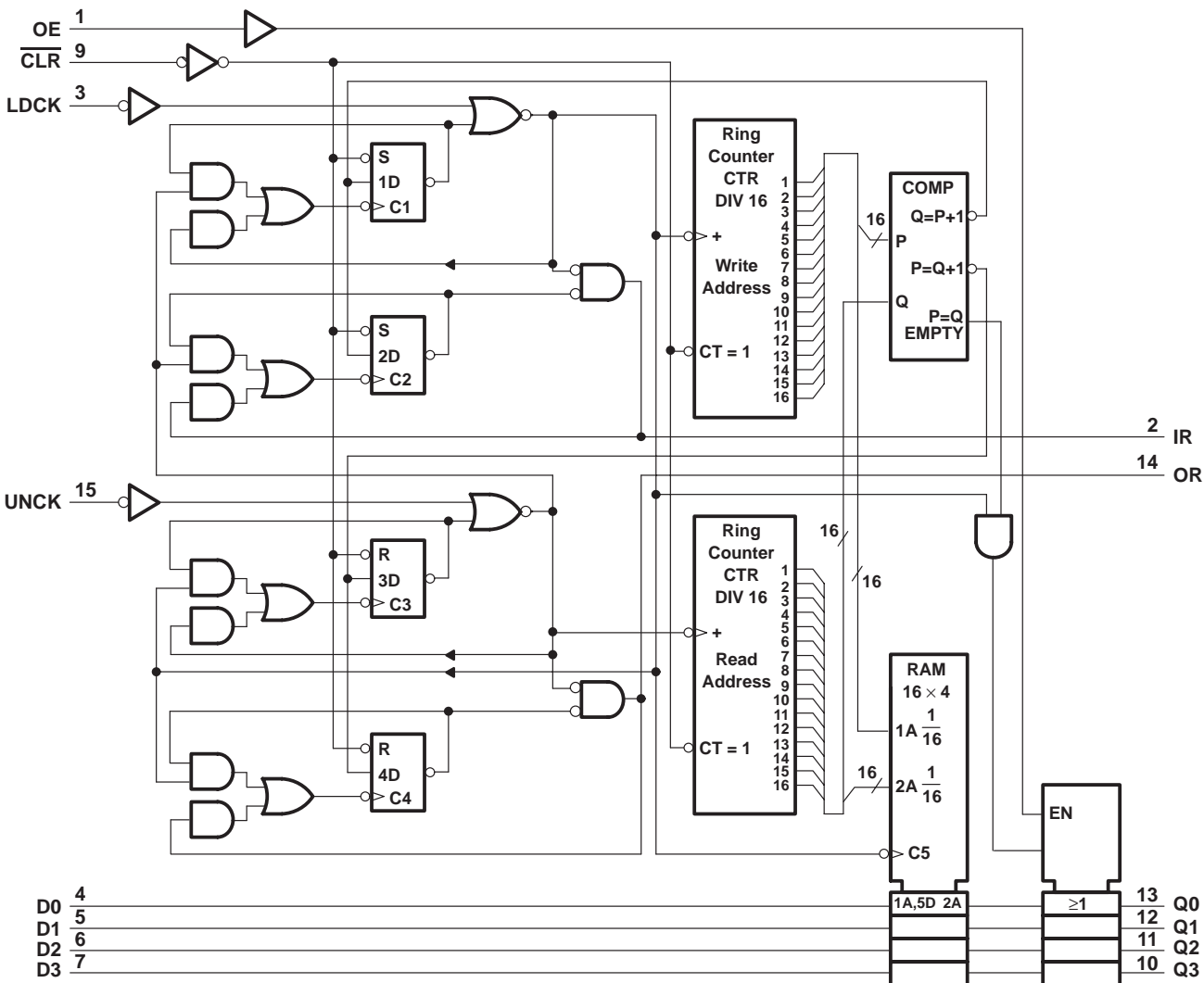

**SN74LS224A**  
**16 × 4 SYNCHRONOUS FIRST-IN, FIRST-OUT MEMORY**  
**WITH 3-STATE OUTPUTS**

SDLS023B – JANUARY 1991 – REVISED APRIL 1998

**schematics of inputs and outputs**

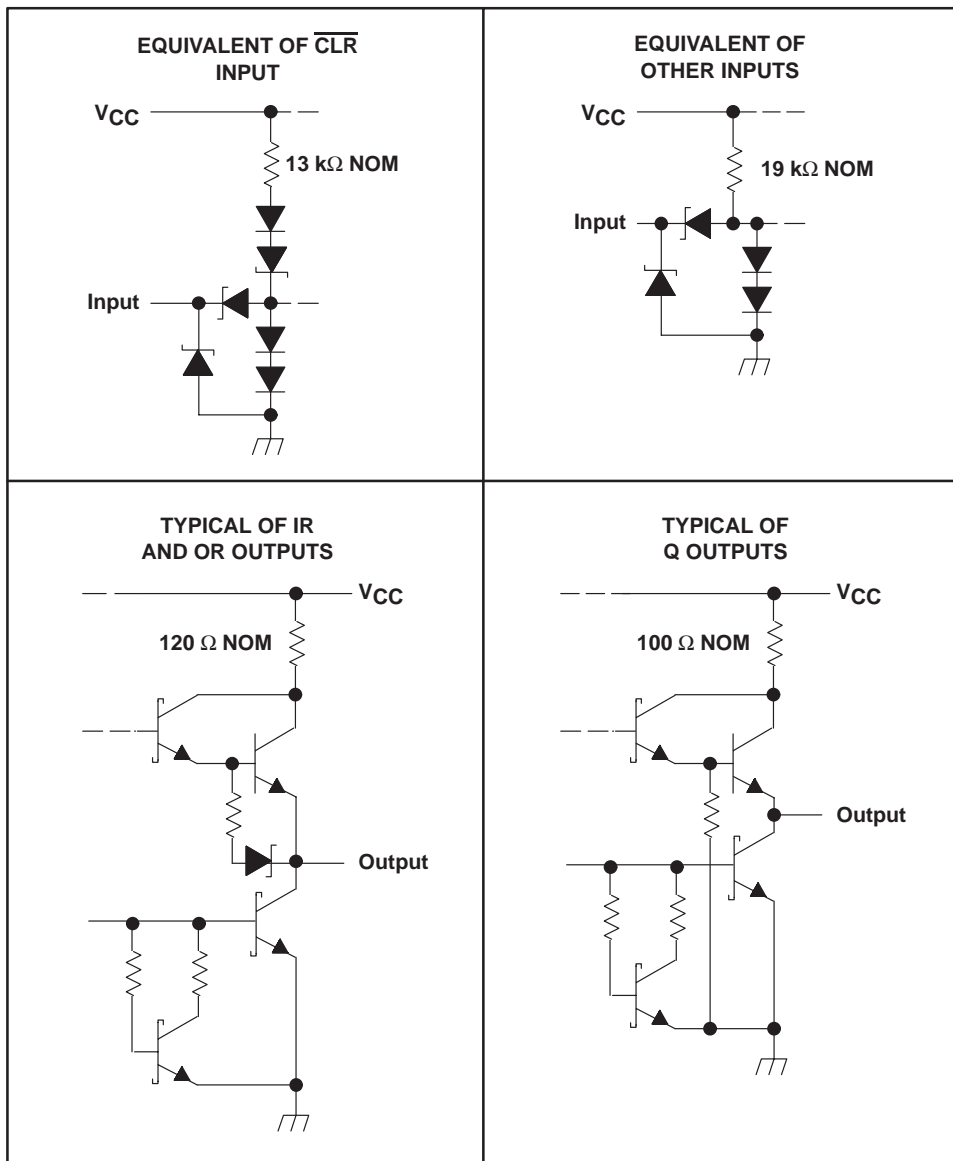

# SN74LS224A

## 16 × 4 SYNCHRONOUS FIRST-IN, FIRST-OUT MEMORY WITH 3-STATE OUTPUTS

SDLS023B – JANUARY 1991 – REVISED APRIL 1998

### timing diagram

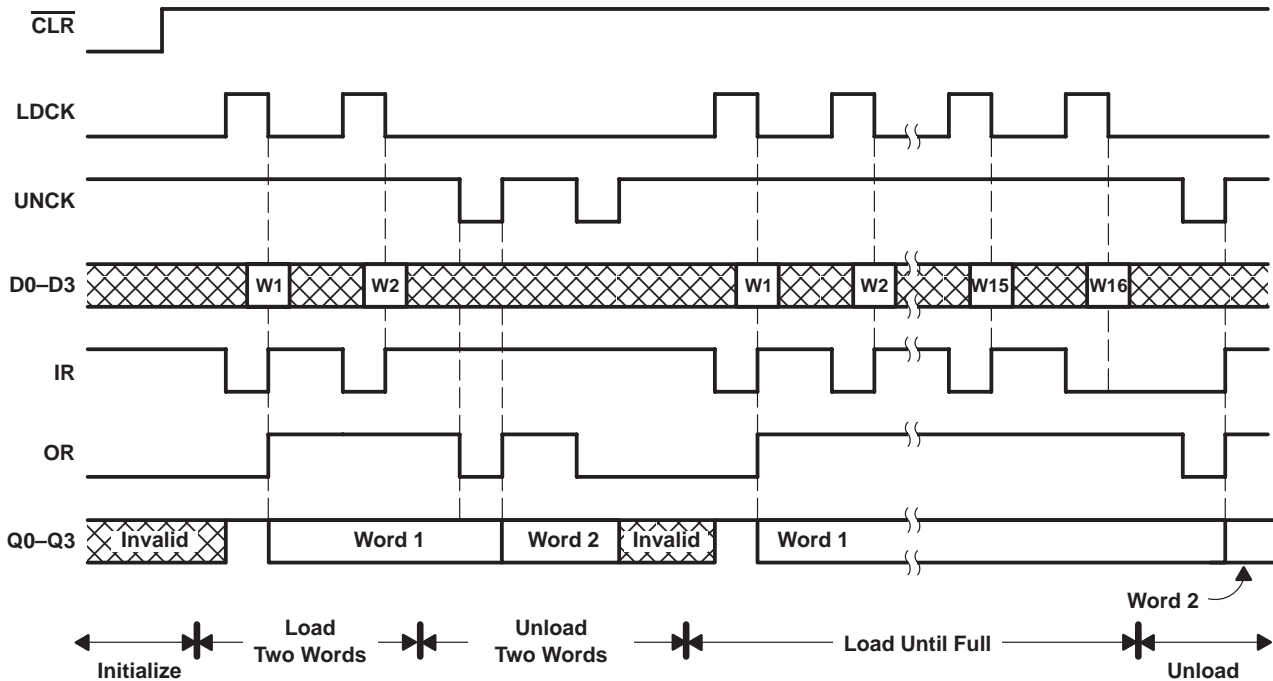

### absolute maximum ratings over operating free-air temperature range (unless otherwise noted)<sup>†</sup>

Supply voltage range, $V_{CC}$ (see Note 1)	.....	-0.5 V to 7 V
Input voltage range, $V_I$	.....	-0.5 V to 7 V
Off-state output voltage range, $V_O$	.....	-0.5 V to 5.5 V
Package thermal impedance, $\theta_{JA}$ (see Note 2)	.....	78°C/W
Storage temperature range, $T_{stg}$	.....	-65°C to 150°C

<sup>†</sup> Stresses beyond those listed under "absolute maximum ratings" may cause permanent damage to the device. These are stress ratings only and functional operation of the device at these or any other conditions beyond those indicated under "recommended operating conditions" is not implied. Exposure to absolute-maximum-rated conditions for extended periods may affect device reliability.

NOTES: 1. All voltage values are with respect to GND.

2. The package thermal impedance is calculated in accordance with JESD 51, except for through-hole packages, which use a trace length of zero.

### recommended operating conditions (see Note 3)

		MIN	NOM	MAX	UNIT
$V_{CC}$	Supply voltage	4.75	5	5.25	V
$V_{IH}$	High-level input voltage	2			V
$V_{IL}$	Low-level input voltage			0.8	V
$I_{OH}$	High-level output current	Q outputs		-2.6	mA
		IR, OR		-0.4	
$I_{OL}$	Low-level output current	Q outputs		24	mA
		IR, OR		8	
$T_A$	Operating free-air temperature	0		70	°C

NOTE 3: To ensure proper operation of this high-speed FIFO device, it is necessary to provide a clean signal to the LDCK and UNCK clock inputs. Any excessive noise or glitching on the clock inputs that violates the  $V_{IL}$ ,  $V_{IH}$ , or minimum pulse-duration limits can cause a false clock or improper operation of the internal read and write pointers.



# SN74LS224A

## 16 × 4 SYNCHRONOUS FIRST-IN, FIRST-OUT MEMORY WITH 3-STATE OUTPUTS

SDLS023B – JANUARY 1991 – REVISED APRIL 1998

electrical characteristics over recommended operating free-air temperature range (unless otherwise noted)

PARAMETER		TEST CONDITIONS		MIN	TYP†	MAX	UNIT
V <sub>IK</sub>		V <sub>CC</sub> = 4.75 V,	I <sub>I</sub> = -18 mA			-1.5	V
V <sub>OH</sub>	Q outputs	V <sub>CC</sub> = 4.75 V,	I <sub>OH</sub> = -2.6 mA	2.4	3.4		V
	IR, OR	V <sub>CC</sub> = 4.75 V,	I <sub>OH</sub> = -0.4 mA	2.7	3.4		
V <sub>OL</sub>	Q outputs	V <sub>CC</sub> = 4.75 V	I <sub>OL</sub> = 12 mA		0.25	0.4	V
			I <sub>OL</sub> = 24 mA		0.35	0.5	
	IR, OR	V <sub>CC</sub> = 4.75 V	I <sub>OL</sub> = 4 mA		0.25	0.4	
			I <sub>OL</sub> = 8 mA		0.35	0.5	
I <sub>OZH</sub>	Q outputs	V <sub>CC</sub> = 5.25 V,	V <sub>O</sub> = 2.7 V			20	μA
I <sub>OZL</sub>	Q outputs	V <sub>CC</sub> = 5.25 V,	V <sub>O</sub> = 0.4 V			-20	μA
I <sub>I</sub>		V <sub>CC</sub> = 5.25 V,	V <sub>I</sub> = 7 V			0.1	mA
I <sub>IH</sub>		V <sub>CC</sub> = 5.25 V,	V <sub>I</sub> = 2.7 V			20	μA
I <sub>IL</sub>		V <sub>CC</sub> = 5.25 V,	V <sub>I</sub> = 0.4 V			-0.4	mA
I <sub>OS</sub> ‡	Q outputs	V <sub>CC</sub> = 5.25 V		-30		-130	mA
	IR, OR			-20		-100	
I <sub>CC</sub>	V <sub>CC</sub> = 5.25 V		Outputs high		84	135	mA
			Outputs low		87	155	
			Outputs disabled		89	155	

† All typical values are at V<sub>CC</sub> = 5 V, T<sub>A</sub> = 25°C.

‡ Not more than one output should be shorted at a time, and duration of the short circuit should not exceed one second.

timing requirements over recommended operating conditions (see Note 3 and Figure 1)

		MIN	NOM	MAX	UNIT
t <sub>w</sub>	Pulse duration	LDCK high		60	ns
		LDCK low		15	
		UNCK low		30	
		UNCK high		30	
		CLR low		20	
t <sub>su</sub>	Setup time	Data to LDCK↓		50	ns
		LDCK↓ before UNCK↓		50	
		UNCK↑ before LDCK↑		50	
t <sub>h</sub>	Hold time	Data from LDCK↓		10	ns

NOTE 3: To ensure proper operation of this high-speed FIFO device, it is necessary to provide a clean signal to the LDCK and UNCK clock inputs. Any excessive noise or glitching on the clock inputs that violates the V<sub>IL</sub>, V<sub>IH</sub>, or minimum pulse-duration limits can cause a false clock or improper operation of the internal read and write pointers.



**SN74LS224A**  
**16 × 4 SYNCHRONOUS FIRST-IN, FIRST-OUT MEMORY**  
**WITH 3-STATE OUTPUTS**

SDLS023B – JANUARY 1991 – REVISED APRIL 1998

switching characteristics,  $V_{CC} = 5\text{ V}$ ,  $T_A = 25^\circ\text{C}$  (see Figure 1)

PARAMETER	FROM (INPUT)	TO (OUTPUT)	TEST CONDITIONS	TYP	MAX	UNIT
$t_{PLH}$	IRE $\uparrow$	IR	$R_L = 2\text{ k}\Omega$ , $C_L = 15\text{ pF}$	N/A	N/A	ns
$t_{PHL}$	IRE $\downarrow$			N/A	N/A	
$t_{PLH}$	ORE $\uparrow$	OR	$R_L = 2\text{ k}\Omega$ , $C_L = 15\text{ pF}$	N/A	N/A	ns
$t_{PHL}$	ORE $\downarrow$			N/A	N/A	
$t_{PLH}$	LDCK $\downarrow$	IR	$R_L = 2\text{ k}\Omega$ , $C_L = 15\text{ pF}$	25	40	ns
$t_{PHL}$	LDCK $\uparrow$			36	50	
$t_{PLH}$	LDCK $\downarrow$	OR	$R_L = 2\text{ k}\Omega$ , $C_L = 15\text{ pF}$	48	70	ns
$t_{PLH}$	UNCK $\uparrow$	OR	$R_L = 2\text{ k}\Omega$ , $C_L = 15\text{ pF}$	29	45	ns
$t_{PHL}$	UNCK $\downarrow$			28	45	
$t_{PLH}$	UNCK $\uparrow$	IR	$R_L = 2\text{ k}\Omega$ , $C_L = 15\text{ pF}$	49	70	ns
$t_{PLH}$	$\overline{\text{CLR}}\downarrow$	IR	$R_L = 2\text{ k}\Omega$ , $C_L = 15\text{ pF}$	36	55	ns
$t_{PHL}$		OR		25	40	
$t_{PHL}$	LDCK $\downarrow$	Q	$R_L = 667\ \Omega$ , $C_L = 45\text{ pF}$	34	50	ns
$t_{PLH}$	UNCK $\uparrow$	Q	$R_L = 667\ \Omega$ , $C_L = 45\text{ pF}$	54	80	ns
$t_{PHL}$				45	70	
$t_{PZL}$	OE $\uparrow$	Q	$R_L = 667\ \Omega$ , $C_L = 45\text{ pF}$	22	35	ns
$t_{PZH}$				21	35	
$t_{PLZ}$	OE $\downarrow$	Q	$R_L = 667\ \Omega$ , $C_L = 5\text{ pF}$	16	30	ns
$t_{PHZ}$				18	30	

**SN74LS224A**  
**16 × 4 SYNCHRONOUS FIRST-IN, FIRST-OUT MEMORY**  
**WITH 3-STATE OUTPUTS**

SDLS023B – JANUARY 1991 – REVISED APRIL 1998

**PARAMETER MEASUREMENT INFORMATION**

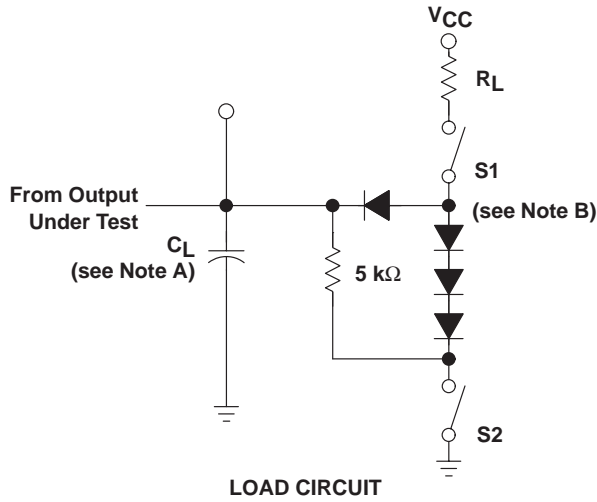

TEST	S1	S2
$t_{pZL}$	Closed	Open
$t_{pZH}$	Open	Closed
$t_{pLZ}/t_{pHZ}$	Closed	Closed
$t_{pLH}/t_{pHL}$	Closed	Closed

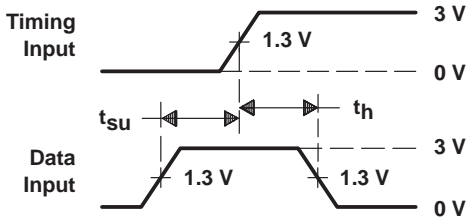

**VOLTAGE WAVEFORMS  
 SETUP AND HOLD TIMES**

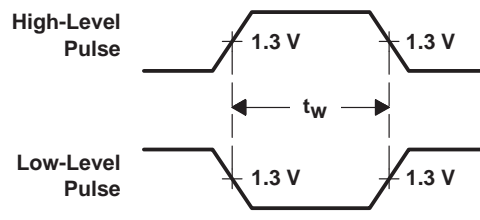

**VOLTAGE WAVEFORMS  
 PULSE DURATIONS**

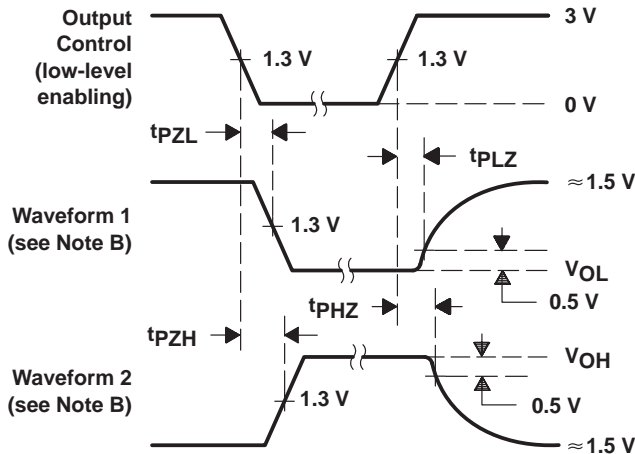

**VOLTAGE WAVEFORMS  
 ENABLE AND DISABLE TIMES, 3-STATE OUTPUTS**

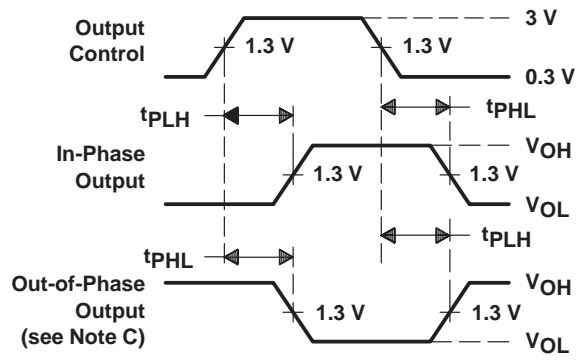

**VOLTAGE WAVEFORMS  
 PROPAGATION DELAY TIMES**

- NOTES: A.  $C_L$  includes probe and jig capacitance.  
 B. Waveform 1 is for an output with internal conditions such that the output is low except when disabled by the output control. Waveform 2 is for an output with internal conditions such that the output is high except when disabled by the output control.  
 C. All input pulses have the following characteristics:  $PRR \leq 1$  MHz,  $t_r < 15$  ns,  $t_f < 6$  ns,  $Z_O \approx 50 \Omega$ .  
 D. All diodes are 1N916 or 1N3064.  
 E. The outputs are measured one at a time with one transition per measurement.

**Figure 1. Load Circuits and Voltage Waveforms**

## IMPORTANT NOTICE

Texas Instruments and its subsidiaries (TI) reserve the right to make changes to their products or to discontinue any product or service without notice, and advise customers to obtain the latest version of relevant information to verify, before placing orders, that information being relied on is current and complete. All products are sold subject to the terms and conditions of sale supplied at the time of order acknowledgement, including those pertaining to warranty, patent infringement, and limitation of liability.

TI warrants performance of its semiconductor products to the specifications applicable at the time of sale in accordance with TI's standard warranty. Testing and other quality control techniques are utilized to the extent TI deems necessary to support this warranty. Specific testing of all parameters of each device is not necessarily performed, except those mandated by government requirements.

CERTAIN APPLICATIONS USING SEMICONDUCTOR PRODUCTS MAY INVOLVE POTENTIAL RISKS OF DEATH, PERSONAL INJURY, OR SEVERE PROPERTY OR ENVIRONMENTAL DAMAGE ("CRITICAL APPLICATIONS"). TI SEMICONDUCTOR PRODUCTS ARE NOT DESIGNED, AUTHORIZED, OR WARRANTED TO BE SUITABLE FOR USE IN LIFE-SUPPORT DEVICES OR SYSTEMS OR OTHER CRITICAL APPLICATIONS. INCLUSION OF TI PRODUCTS IN SUCH APPLICATIONS IS UNDERSTOOD TO BE FULLY AT THE CUSTOMER'S RISK.

In order to minimize risks associated with the customer's applications, adequate design and operating safeguards must be provided by the customer to minimize inherent or procedural hazards.

TI assumes no liability for applications assistance or customer product design. TI does not warrant or represent that any license, either express or implied, is granted under any patent right, copyright, mask work right, or other intellectual property right of TI covering or relating to any combination, machine, or process in which such semiconductor products or services might be or are used. TI's publication of information regarding any third party's products or services does not constitute TI's approval, warranty or endorsement thereof.