

SN54LS245, SN74LS245 OCTAL BUS TRANSCEIVERS WITH 3-STATE OUTPUTS

SDLS146

OCTOBER 1976 - REVISED MARCH 1988

- Bi-directional Bus Transceiver in a High-Density 20-Pin Package
- 3-State Outputs Drive Bus Lines Directly
- PNP Inputs Reduce D-C Loading on Bus Lines
- Hysteresis at Bus Inputs Improve Noise Margins
- Typical Propagation Delay Times, Port-to-Port . . . 8 ns

SN54LS245 . . . J OR W PACKAGE
SN74LS245 . . . DW OR N PACKAGE
(TOP VIEW)

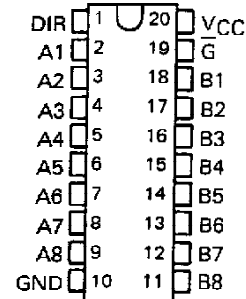

TYPE	I _{OL} (SINK CURRENT)	I _{OH} (SOURCE CURRENT)
SN54LS245	12 mA	-12 mA
SN74LS245	24 mA	-15 mA

SN54LS245 . . . FK PACKAGE
(TOP VIEW)

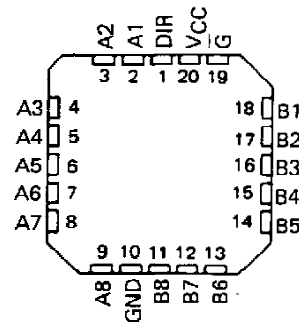

description

These octal bus transceivers are designed for asynchronous two-way communication between data buses. The control function implementation minimizes external timing requirements.

The devices allow data transmission from the A bus to the B bus or from the B bus to the A bus depending upon the logic level at the direction control (DIR) input. The enable input (\bar{G}) can be used to disable the device so that the buses are effectively isolated.

The SN54LS245 is characterized for operation over the full military temperature range of -55°C to 125°C . The SN74LS245 is characterized for operation from 0°C to 70°C .

schematics of inputs and outputs

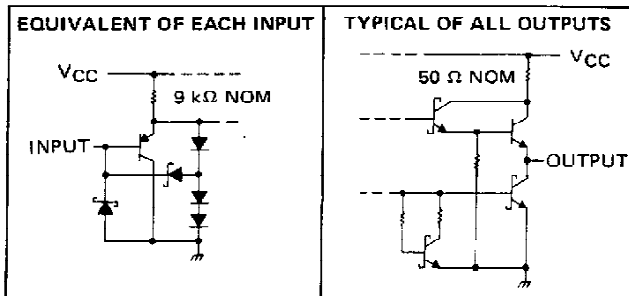

FUNCTION TABLE

ENABLE \bar{G}	DIRECTION CONTROL DIR	OPERATION
L	L	B data to A bus
L	H	A data to B bus
H	X	Isolation

H = high level, L = low level, X = irrelevant

PRODUCTION DATA documents contain information current as of publication date. Products conform to specifications per the terms of Texas Instruments standard warranty. Production processing does not necessarily include testing of all parameters.

**TEXAS
INSTRUMENTS**

POST OFFICE BOX 655012 • DALLAS, TEXAS 75265

SN54LS245, SN74LS245 OCTAL BUS TRANSCEIVERS WITH 3-STATE OUTPUTS

logic symbol†

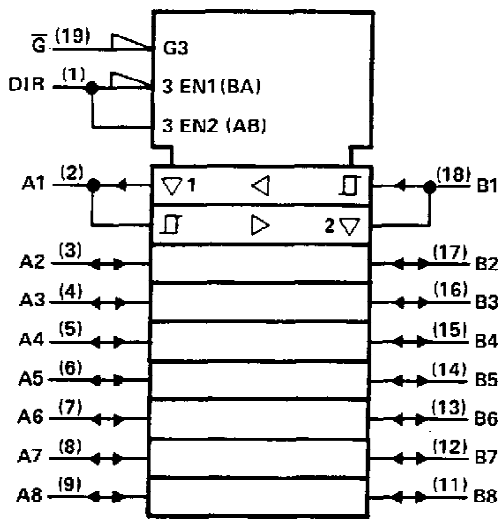

†This symbol is in accordance with ANSI/IEEE Std. 91-1984 and IEC Publication 617-12.
Pin numbers shown are for DW, J, N, and W packages.

logic diagram (positive logic)

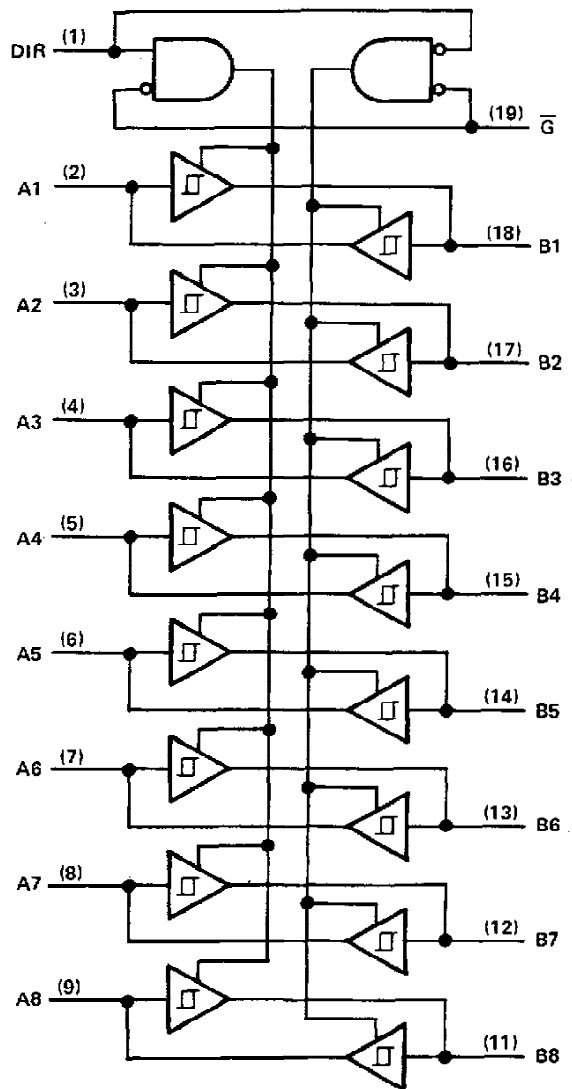

absolute maximum ratings over operating free-air temperature range (unless otherwise noted)

Supply voltage, V_{CC} (see Note 1)	7 V
Input voltage	7 V
Off-state output voltage	5.5 V
Operating free-air temperature range: SN54LS245	-55°C to 125°C
SN74LS245	0°C to 70°C
Storage temperature range	-65°C to 150°C

NOTE 1: Voltage values are with respect to network ground terminal.



POST OFFICE BOX 655012 • DALLAS, TEXAS 75265

SN54LS245, SN74LS245 OCTAL BUS TRANSCEIVERS WITH 3-STATE OUTPUTS

recommended operating conditions

PARAMETER	SN54LS245			SN74LS245			UNIT
	MIN	NOM	MAX	MIN	NOM	MAX	
Supply voltage, V_{CC}	4.5	5	5.5	4.75	5	5.25	V
High-level output current, I_{OH}			-12			-15	mA
Low-level output current, I_{OL}			12			24	mA
Operating free-air temperature, T_A	-55		125	0		70	°C

electrical characteristics over recommended operating free-air temperature range (unless otherwise noted)

PARAMETER	TEST CONDITIONS†	SN54LS245			SN74LS245			UNIT	
		MIN	TYP‡	MAX	MIN	TYP‡	MAX		
V_{IH} High-level input voltage		2			2			V	
V_{IL} Low-level input voltage				0.7			0.8	V	
V_{IK} Input clamp voltage	$V_{CC} = \text{MIN}$, $I_I = -18 \text{ mA}$			-1.5			-1.5	V	
Hysteresis ($V_{T+} - V_{T-}$) A or B input	$V_{CC} = \text{MIN}$	0.2	0.4		0.2	0.4		V	
V_{OH} High-level output voltage	$V_{CC} = \text{MIN}$, $V_{IH} = 2 \text{ V}$, $V_{IL} = V_{IL \text{ max}}$	$I_{OH} = -3 \text{ mA}$	2.4	3.4		2.4	3.4		V
		$I_{OH} = \text{MAX}$	2			2			
V_{OL} Low-level output voltage	$V_{CC} = \text{MIN}$, $V_{IH} = 2 \text{ V}$, $V_{IL} = V_{IL \text{ max}}$	$I_{OL} = 12 \text{ mA}$		0.4			0.4		V
		$I_{OL} = 24 \text{ mA}$					0.5		
I_{OZH} Off-state output current, high-level voltage applied	$V_{CC} = \text{MAX}$, \bar{G} at 2 V	$V_O = 2.7 \text{ V}$		20			20		μA
I_{OZL} Off-state output current, low-level voltage applied		$V_O = 0.4 \text{ V}$		-200			-200		
I_I Input current at maximum input voltage	A or B DIR or \bar{G}	$V_{CC} = \text{MAX}$	$V_I = 5.5 \text{ V}$		0.1		0.1		mA
			$V_I = 7 \text{ V}$		0.1		0.1		
I_{IH} High-level input current	$V_{CC} = \text{MAX}$, $V_{IH} = 2.7 \text{ V}$			20			20	μA	
I_{IL} Low-level input current	$V_{CC} = \text{MAX}$, $V_{IL} = 0.4 \text{ V}$			-0.2			-0.2	mA	
I_{OS} Short-circuit output current‡	$V_{CC} = \text{MAX}$	-40		-225	-40		-225	mA	
I_{CC} Supply current	Total, outputs high		48	70		48	70		mA
	Total, outputs low		62	90		62	90		
	Outputs at Hi-Z		64	95		64	95		

†For conditions shown as MIN or MAX, use the appropriate value specified under recommended operating conditions.

‡All typical values are at $V_{CC} = 5 \text{ V}$, $T_A = 25^\circ\text{C}$.

§Not more than one output should be shorted at a time, and duration of the short-circuit should not exceed one second.

switching characteristics, $V_{CC} = 5 \text{ V}$, $T_A = 25^\circ\text{C}$

PARAMETER	TEST CONDITIONS	MIN	TYP	MAX	UNIT	
t_{PLH} Propagation delay time, low-to-high-level output	$C_L = 45 \text{ pF}$, $R_L = 667 \Omega$, See Note 2		8	12	ns	
t_{PHL} Propagation delay time, high-to-low-level output			8	12	ns	
t_{PZL} Output enable time to low level				27	40	ns
t_{PZH} Output enable time to high level				25	40	ns
t_{PLZ} Output disable time from low level	$C_L = 5 \text{ pF}$, $R_L = 667 \Omega$, See Note 2		15	25	ns	
t_{PHZ} Output disable time from high level			15	28	ns	

NOTE 2: Load circuits and voltage waveforms are shown in Section 1.

TEXAS
INSTRUMENTS

POST OFFICE BOX 655012 • DALLAS, TEXAS 75265

IMPORTANT NOTICE

Texas Instruments (TI) reserves the right to make changes to its products or to discontinue any semiconductor product or service without notice, and advises its customers to obtain the latest version of relevant information to verify, before placing orders, that the information being relied on is current.

TI warrants performance of its semiconductor products and related software to the specifications applicable at the time of sale in accordance with TI's standard warranty. Testing and other quality control techniques are utilized to the extent TI deems necessary to support this warranty. Specific testing of all parameters of each device is not necessarily performed, except those mandated by government requirements.

Certain applications using semiconductor products may involve potential risks of death, personal injury, or severe property or environmental damage ("Critical Applications").

TI SEMICONDUCTOR PRODUCTS ARE NOT DESIGNED, INTENDED, AUTHORIZED, OR WARRANTED TO BE SUITABLE FOR USE IN LIFE-SUPPORT APPLICATIONS, DEVICES OR SYSTEMS OR OTHER CRITICAL APPLICATIONS.

Inclusion of TI products in such applications is understood to be fully at the risk of the customer. Use of TI products in such applications requires the written approval of an appropriate TI officer. Questions concerning potential risk applications should be directed to TI through a local SC sales office.

In order to minimize risks associated with the customer's applications, adequate design and operating safeguards should be provided by the customer to minimize inherent or procedural hazards.

TI assumes no liability for applications assistance, customer product design, software performance, or infringement of patents or services described herein. Nor does TI warrant or represent that any license, either express or implied, is granted under any patent right, copyright, mask work right, or other intellectual property right of TI covering or relating to any combination, machine, or process in which such semiconductor products or services might be or are used.

IMPORTANT NOTICE

Texas Instruments (TI) reserves the right to make changes to its products or to discontinue any semiconductor product or service without notice, and advises its customers to obtain the latest version of relevant information to verify, before placing orders, that the information being relied on is current.

TI warrants performance of its semiconductor products and related software to the specifications applicable at the time of sale in accordance with TI's standard warranty. Testing and other quality control techniques are utilized to the extent TI deems necessary to support this warranty. Specific testing of all parameters of each device is not necessarily performed, except those mandated by government requirements.

Certain applications using semiconductor products may involve potential risks of death, personal injury, or severe property or environmental damage ("Critical Applications").

TI SEMICONDUCTOR PRODUCTS ARE NOT DESIGNED, INTENDED, AUTHORIZED, OR WARRANTED TO BE SUITABLE FOR USE IN LIFE-SUPPORT APPLICATIONS, DEVICES OR SYSTEMS OR OTHER CRITICAL APPLICATIONS.

Inclusion of TI products in such applications is understood to be fully at the risk of the customer. Use of TI products in such applications requires the written approval of an appropriate TI officer. Questions concerning potential risk applications should be directed to TI through a local SC sales office.

In order to minimize risks associated with the customer's applications, adequate design and operating safeguards should be provided by the customer to minimize inherent or procedural hazards.

TI assumes no liability for applications assistance, customer product design, software performance, or infringement of patents or services described herein. Nor does TI warrant or represent that any license, either express or implied, is granted under any patent right, copyright, mask work right, or other intellectual property right of TI covering or relating to any combination, machine, or process in which such semiconductor products or services might be or are used.