

# SN5474, SN54LS74A, SN54S74, SN7474, SN74LS74A, SN74S74

## SDLS119 DUAL D-TYPE POSITIVE-EDGE-TRIGGERED FLIP-FLOPS WITH PRESET AND CLEAR

DECEMBER 1983 — REVISED MARCH 1988

- Package Options Include Plastic "Small Outline" Packages, Ceramic Chip Carriers and Flat Packages, and Plastic and Ceramic DIPs
- Dependable Texas Instruments Quality and Reliability

### description

These devices contain two independent D-type positive-edge-triggered flip-flops. A low level at the preset or clear inputs sets or resets the outputs regardless of the levels of the other inputs. When preset and clear are inactive (high), data at the D input meeting the setup time requirements are transferred to the outputs on the positive-going edge of the clock pulse. Clock triggering occurs at a voltage level and is not directly related to the rise time of the clock pulse. Following the hold time interval, data at the D input may be changed without affecting the levels at the outputs.

The SN54' family is characterized for operation over the full military temperature range of  $-55^{\circ}\text{C}$  to  $125^{\circ}\text{C}$ . The SN74' family is characterized for operation from  $0^{\circ}\text{C}$  to  $70^{\circ}\text{C}$ .

FUNCTION TABLE

INPUTS				OUTPUTS	
PRE	CLR	CLK	D	Q	$\bar{Q}$
L	H	X	X	H	L
H	L	X	X	L	H
L	L	X	X	H <sup>†</sup>	H <sup>†</sup>
H	H	↑	H	H	L
H	H	↑	L	L	H
H	H	L	X	Q <sub>0</sub>	$\bar{Q}_0$

† The output levels in this configuration are not guaranteed to meet the minimum levels in  $V_{OH}$  if the lows at preset and clear are near  $V_{IL}$  maximum. Furthermore, this configuration is nonstable; that is, it will not persist when either preset or clear returns to its inactive (high) level.

### logic symbol<sup>‡</sup>

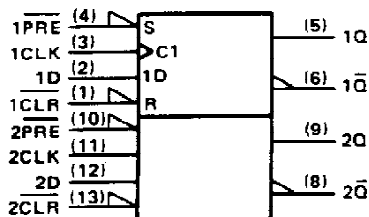

<sup>‡</sup>This symbol is in accordance with ANSI/IEEE Std 91-1984 and IEC Publication 617-12. Pin numbers shown are for D, J, N, and W packages.

SN5474 . . . J PACKAGE  
SN54LS74A, SN54S74 . . . J OR W PACKAGE  
SN7474 . . . N PACKAGE  
SN74LS74A, SN74S74 . . . D OR N PACKAGE

(TOP VIEW)

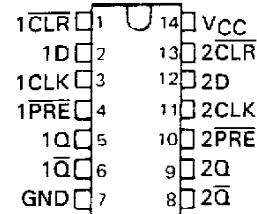

SN5474 . . . W PACKAGE  
(TOP VIEW)

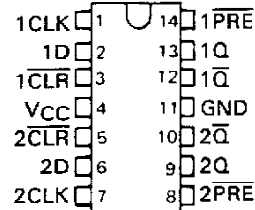

SN54LS74A, SN54S74 . . . FK PACKAGE  
(TOP VIEW)

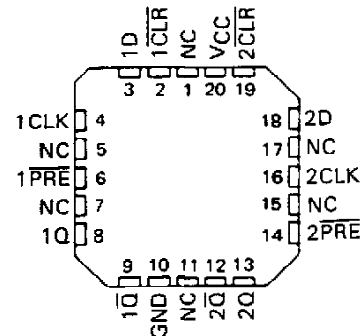

NC - No internal connection

### logic diagram (positive logic)

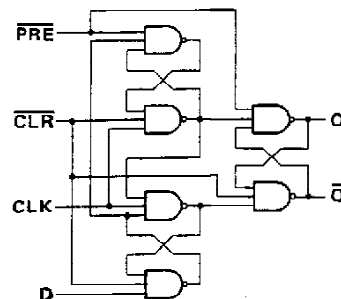

PRODUCTION DATA documents contain information current as of publication date. Products conform to specifications per the terms of Texas Instruments standard warranty. Production processing does not necessarily include testing of all parameters.

TEXAS  
INSTRUMENTS

POST OFFICE BOX 655012 • DALLAS, TEXAS 75265

**SN5474, SN7474, SN54S74, SN74S74**  
**DUAL D-TYPE POSITIVE-EDGE-TRIGGERED FLIP-FLOPS WITH PRESET AND CLEAR**

schematics of inputs and outputs

74

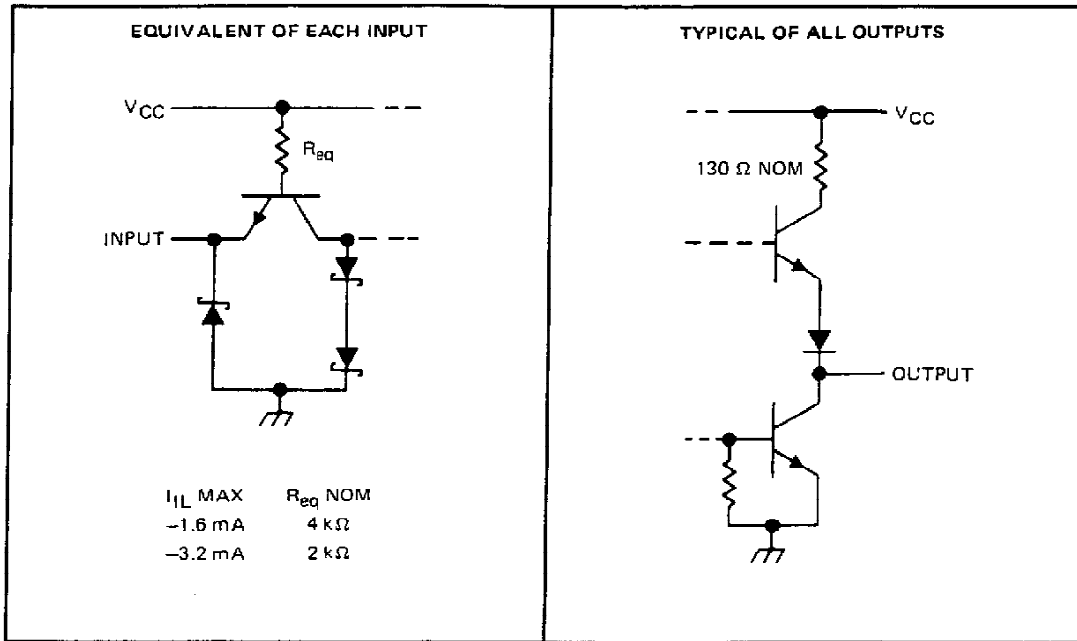

'S74

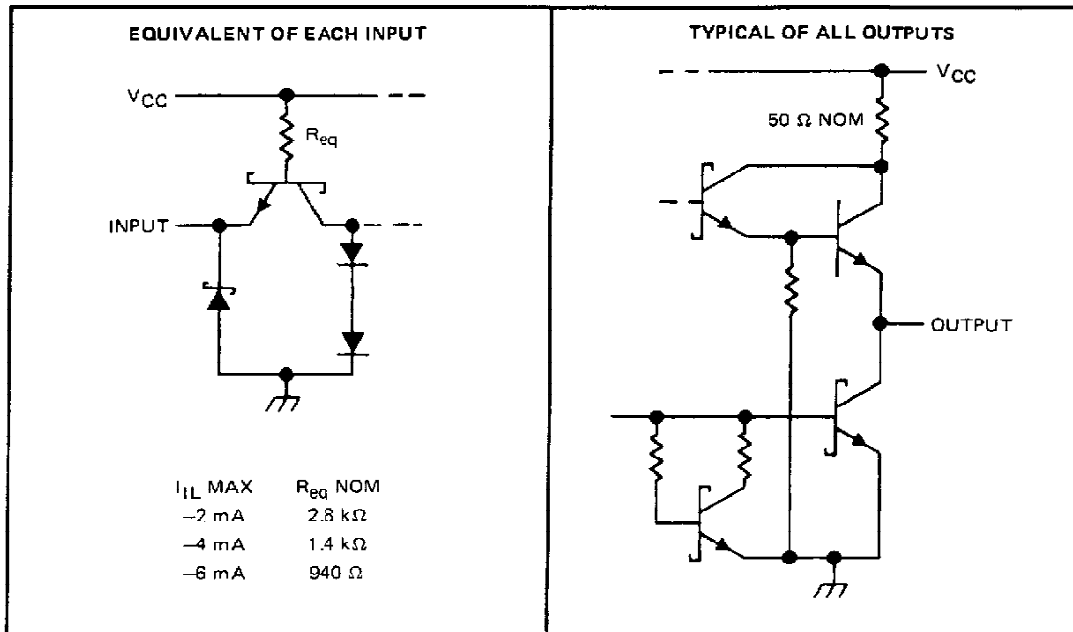

**SN5474, SN54LS74A, SN54S74,  
SN7474, SN74LS74A, SN74S74**

**DUAL D-TYPE POSITIVE-EDGE-TRIGGERED FLIP-FLOPS WITH PRESET AND CLEAR**

schematic

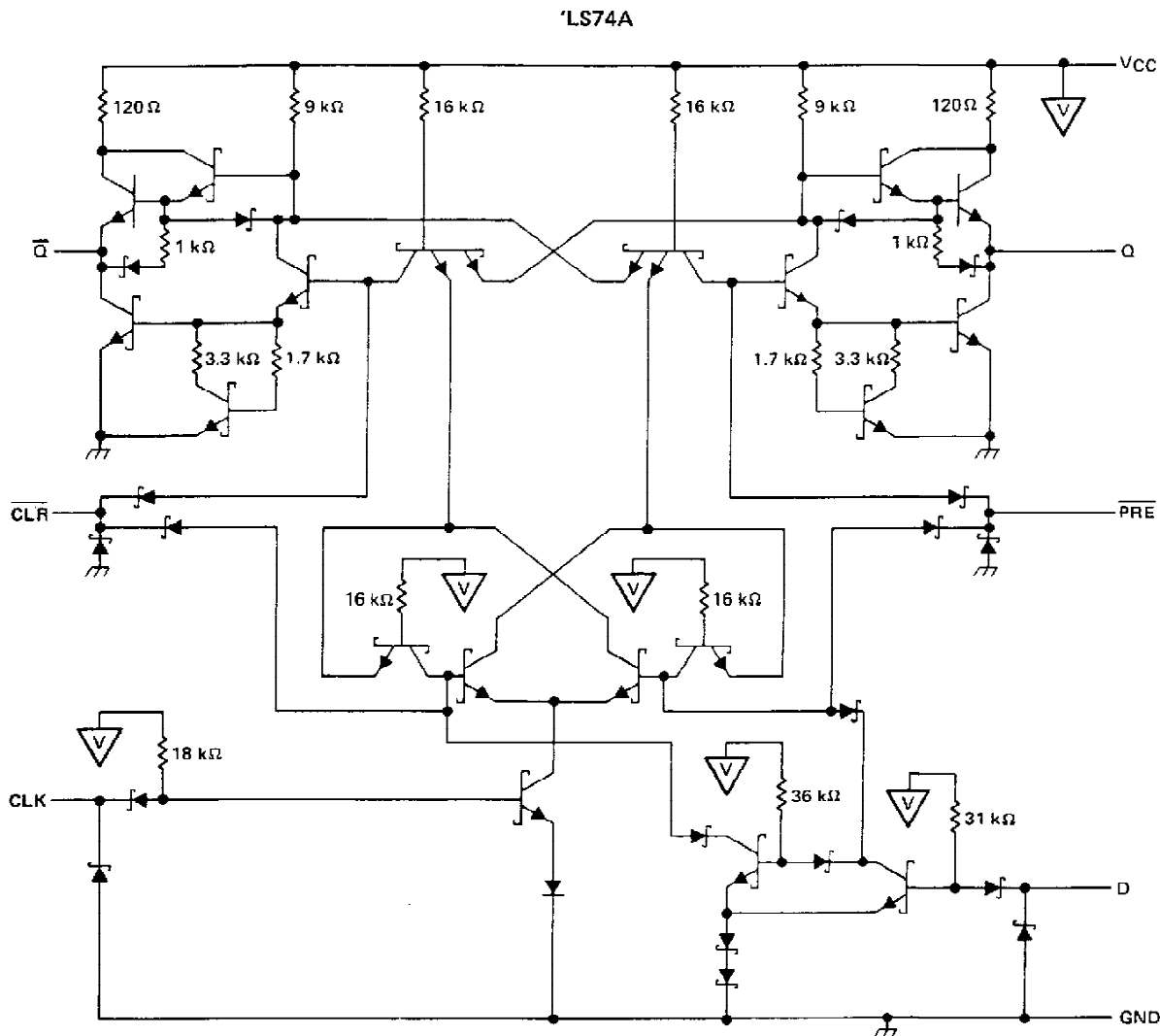

absolute maximum ratings over operating free-air temperature range (unless otherwise noted)

Supply voltage, $V_{CC}$ (see Note 1) .....	7 V
Input voltage: '74, 'S74 .....	5.5 V
'LS74A .....	7 V
Operating free-air temperature range: SN54' .....	-55°C to 125°C
SN74' .....	0°C to 70°C
Storage temperature range .....	-65°C to 150°C

NOTE 1: Voltage values are with respect to network ground terminal.

**TEXAS  
INSTRUMENTS**

POST OFFICE BOX 655012 • DALLAS, TEXAS 75265

# SN5474, SN7474

## DUAL D-TYPE POSITIVE-EDGE-TRIGGERED FLIP-FLOPS WITH PRESET AND CLEAR

### recommended operating conditions

		SN5474			SN7474			UNIT
		MIN	NOM	MAX	MIN	NOM	MAX	
V <sub>CC</sub>	Supply voltage	4.5	5	5.5	4.75	5	5.25	V
V <sub>IH</sub>	High-level input voltage	2			2			V
V <sub>IL</sub>	Low-level input voltage	0.8			0.8			V
I <sub>OH</sub>	High-level output current	-0.4			-0.4			mA
I <sub>OL</sub>	Low-level output current	16			16			mA
t <sub>w</sub>	Pulse duration	CLK high	30		30			ns
		CLK low	37		37			
		PRE or CLR low	30		30			
t <sub>su</sub>	Input setup time before CLK †	20			20			ns
t <sub>h</sub>	Input hold time-data after CLK †	5			5			ns
T <sub>A</sub>	Operating free-air temperature	-55		125		0		70 °C

### electrical characteristics over recommended operating free-air temperature range (unless otherwise noted)

PARAMETER	TEST CONDITIONS†	SN5474			SN7474			UNIT
		MIN	TYP‡	MAX	MIN	TYP‡	MAX	
V <sub>IK</sub>	V <sub>CC</sub> = MIN, I <sub>I</sub> = -12 mA	-1.5			-1.5			V
V <sub>OH</sub>	V <sub>CC</sub> = MIN, V <sub>IH</sub> = 2 V, V <sub>IL</sub> = 0.8 V, I <sub>OH</sub> = -0.4 mA	2.4	3.4		2.4	3.4		V
V <sub>OL</sub>	V <sub>CC</sub> = MIN, V <sub>IH</sub> = 2 V, V <sub>IL</sub> = 0.8 V, I <sub>OL</sub> = 16 mA	0.2	0.4		0.2	0.4		V
I <sub>I</sub>	V <sub>CC</sub> = MAX, V <sub>I</sub> = 5.5 V	1			1			mA
I <sub>IH</sub>	D	40			40			μA
	CLR	120			120			
	All Other	80			80			
I <sub>IL</sub>	D	-1.6			-1.6			mA
	PRE‡	-1.6			-1.6			
	CLR‡	-3.2			-3.2			
	CLK	-3.2			-3.2			
I <sub>OS</sub> ‡	V <sub>CC</sub> = MAX	-20	-57	-18	-57		mA	
I <sub>CC</sub> #	V <sub>CC</sub> = MAX, See Note 2	8.5	15	8.5	15		mA	

†For conditions shown as MIN or MAX, use the appropriate value specified under recommended operating conditions.

‡All typical values are at V<sub>CC</sub> = 5 V, T<sub>A</sub> = 25°C.

§Clear is tested with preset high and preset is tested with clear high.

¶Not more than one output should be shown at a time.

#Average per flip-flop.

NOTE 2: With all outputs open, I<sub>CC</sub> is measured with the Q and  $\bar{Q}$  outputs high in turn. At the time of measurement, the clock input is grounded.

### switching characteristics, V<sub>CC</sub> = 5 V, T<sub>A</sub> = 25°C (see note 3)

PARAMETER	FROM (INPUT)	TO (OUTPUT)	TEST CONDITIONS	MIN	TYP	MAX	UNIT
f <sub>max</sub>			R <sub>L</sub> = 400 Ω, C <sub>L</sub> = 15 pF	15	25		MHz
‡PLH	$\overline{\text{PRE}}$ or $\overline{\text{CLR}}$	Q or $\bar{Q}$				25	ns
‡PHL						40	ns
‡PLH	CLK	Q or $\bar{Q}$			14	25	ns
‡PHL					20	40	ns

NOTE 3: Load circuits and voltage waveforms are shown in Section 1.



POST OFFICE BOX 655012 • DALLAS, TEXAS 75265

# SN54LS74A, SN74LS74A

## DUAL D-TYPE POSITIVE-EDGE-TRIGGERED FLIP-FLOPS WITH PRESET AND CLEAR

### recommended operating conditions

		SN54LS74A			SN74LS74A			UNIT
		MIN	NOM	MAX	MIN	NOM	MAX	
$V_{CC}$	Supply voltage	4.5	b	5.5	4.75	5	5.25	V
$V_{IH}$	High-level input voltage	2			2			V
$V_{IL}$	Low-level input voltage			0.7			0.8	V
$I_{OH}$	High-level output current			-0.4			-0.4	mA
$I_{OL}$	Low-level output current			4			8	mA
$f_{clock}$	Clock frequency	0		25	0		25	MHz
$t_w$	Pulse duration	CLK high		25	25			ns
		PRE or CLR low		25	25			
$t_{su}$	Setup time-before CLK $\uparrow$	High-level data		20	20			ns
		Low-level data		20	20			
$t_h$	Hold time-data after CLK $\uparrow$	5		5			ns	
$T_A$	Operating free-air temperature	-55		125	0		70	$^{\circ}$ C

### electrical characteristics over recommended operating free-air temperature range (unless otherwise noted)

PARAMETER		TEST CONDITIONS <sup>†</sup>	SN54LS74A			SN74LS74A			UNIT
			MIN	TYP <sup>‡</sup>	MAX	MIN	TYP <sup>‡</sup>	MAX	
$V_{IK}$		$V_{CC} = \text{MIN}, I_I = -18 \text{ mA}$	-1.5			-1.5			V
$V_{OH}$		$V_{CC} = \text{MIN}, V_{IH} = 2 \text{ V}, V_{IL} = \text{MAX}, I_{OH} = -0.4 \text{ mA}$	2.5	3.4		2.7	3.4		V
$V_{OL}$		$V_{CC} = \text{MIN}, V_{IL} = \text{MAX}, V_{IH} = 2 \text{ V}, I_{OL} = 4 \text{ mA}$	0.25	0.4		0.25	0.4		V
		$V_{CC} = \text{MIN}, V_{IL} = \text{MAX}, V_{IH} = 2 \text{ V}, I_{OL} = 8 \text{ mA}$				0.35	0.5		
$I_I$	D or CLK	$V_{CC} = \text{MAX}, V_I = 7 \text{ V}$	0.1			0.1			mA
	CLR or PRE		0.2			0.2			
$I_{IH}$	D or CLK	$V_{CC} = \text{MAX}, V_I = 2.7 \text{ V}$	20			20			$\mu$ A
	CLR or PRE		40			40			
$I_{IL}$	D or CLK	$V_{CC} = \text{MAX}, V_I = 0.4 \text{ V}$	-0.4			-0.4			mA
	CLR or PRE		-0.8			-0.8			
$I_{OS}^{\S}$		$V_{CC} = \text{MAX},$ See Note 4	-20	-100		-20	-100		mA
$I_{CC}$ (Total)		$V_{CC} = \text{MAX},$ See Note 2	4	8		4	8		mA

<sup>†</sup> For conditions shown as MIN or MAX, use the appropriate value specified under recommended operating conditions.

<sup>‡</sup> All typical values are at  $V_{CC} = 5 \text{ V}, T_A = 25^{\circ}\text{C}$ .

<sup>§</sup> Not more than one output should be shorted at a time, and the duration of the short circuit should not exceed one second.

NOTE 2: With all outputs open,  $I_{CC}$  is measured with the Q and  $\bar{Q}$  outputs high in turn. At the time of measurement, the clock input is grounded.

NOTE 4: For certain devices where state commutation can be caused by shorting an output to ground, an equivalent test may be performed with  $V_O = 2.25 \text{ V}$  and  $2.125 \text{ V}$  for the 54 family and the 74 family, respectively, with the minimum and maximum limits reduced to one half of their stated values.

### switching characteristics, $V_{CC} = 5 \text{ V}, T_A = 25^{\circ}\text{C}$ (see note 3)

PARAMETER	FROM (INPUT)	TO (OUTPUT)	TEST CONDITIONS	MIN	TYP	MAX	UNIT
$f_{max}$			$R_L = 2 \text{ k}\Omega, C_L = 15 \text{ pF}$	25	33		MHz
$t_{PLH}$	$\overline{\text{CLR}}, \overline{\text{PRE}}$ or CLK	Q or $\bar{Q}$		13	25		ns
$t_{PHL}$				25	40		ns

Note 3: Load circuits and voltage waveforms are shown in Section 1.

  
**TEXAS  
INSTRUMENTS**

POST OFFICE BOX 655012 • DALLAS, TEXAS 75265

# SN54S74, SN74S74

## DUAL D-TYPE POSITIVE-EDGE-TRIGGERED FLIP-FLOPS WITH PRESET AND CLEAR

### recommended operating conditions

		SN54S74			SN74S74			UNIT
		MIN	NOM	MAX	MIN	NOM	MAX	
$V_{CC}$	Supply voltage	4.5	5	5.5	4.75	5	5.25	V
$V_{IH}$	High-level input voltage	2			2			V
$V_{IL}$	Low-level input voltage			0.8			0.8	V
$I_{OH}$	High-level output current			-1			-1	mA
$I_{OL}$	Low-level output current			20			20	mA
$t_w$	Pulse duration	CLK high	6		6			ns
		CLK low	7.3		7.3			
		$\overline{CLR}$ or $\overline{PRE}$ low	7		7			
$t_{su}$	Setup time, before CLK $\uparrow$	High-level data	3		3			ns
		Low-level data	3		3			
$t_h$	Input hold time - data after CLK $\uparrow$	2			2			ns
$T_A$	Operating free-air temperature	-55		125	0		70	$^{\circ}C$

### electrical characteristics over recommended operating free-air temperature range (unless otherwise noted)

PARAMETER	TEST CONDITIONS <sup>†</sup>	SN54S74			SN74S74			UNIT
		MIN	TYP <sup>‡</sup>	MAX	MIN	TYP <sup>‡</sup>	MAX	
$V_{IK}$	$V_{CC} = \text{MIN.}$ , $I_I = -18 \text{ mA.}$			-1.2			-1.2	V
$V_{OH}$	$V_{CC} = \text{MIN.}$ , $V_{IH} = 2 \text{ V.}$ , $V_{IL} = 0.8 \text{ V.}$ , $I_{OH} = -1 \text{ mA}$	2.5	3.4		2.7	3.4		V
$V_{OL}$	$V_{CC} = \text{MIN.}$ , $V_{IH} = 2 \text{ V.}$ , $V_{IL} = 0.8 \text{ V.}$ , $I_{OL} = 20 \text{ mA}$			0.5			0.5	V
$I_I$	$V_{CC} = \text{MAX.}$ , $V_I = 5.5 \text{ V}$			1			1	mA
$I_{IH}$	D			50			50	$\mu\text{A}$
	$\overline{CLR}$	$V_{CC} = \text{MAX.}$ , $V_I = 2.7 \text{ V}$		150			150	
	$\overline{PRE}$ or CLK			100			100	
$I_{IL}$	D			-2			-2	mA
	$\overline{CLR}$ <sup>†</sup>	$V_{CC} = \text{MAX.}$ , $V_I = 0.5 \text{ V}$		-6			-6	
	$\overline{PRE}$ <sup>†</sup>			-4			-4	
	CLK			-4			-4	
$I_{OS}$ <sup>§</sup>	$V_{CC} = \text{MAX.}$	-40		-100	-40		-100	mA
$I_{CC}$ <sup>#</sup>	$V_{CC} = \text{MAX.}$ , See Note 2		15	25		15	25	mA

<sup>†</sup>For conditions shown as MIN or MAX, use the appropriate value specified under recommended operating conditions.

<sup>‡</sup>All typical values are at  $V_{CC} = 5 \text{ V}$ ,  $T_A = 25^{\circ}C$ .

<sup>§</sup>Not more than one output should be shorted at a time, and the duration of the short circuit should not exceed one second.

<sup>†</sup>Clear is tested with preset high and preset is tested with clear high.

<sup>#</sup>Average per flip-flop.

NOTE 2: With all outputs open,  $I_{CC}$  is measured with the Q and  $\overline{Q}$  outputs high in turn. At the time of measurement, the clock input is grounded.

### switching characteristics, $V_{CC} = 5 \text{ V}$ , $T_A = 25^{\circ}C$ (see note 3)

PARAMETER	FROM (INPUT)	TO (OUTPUT)	TEST CONDITIONS	MIN	TYP	MAX	UNIT
$f_{max}$				75	110		MHz
$t_{PLH}$	$\overline{PRE}$ or $\overline{CLR}$	Q or $\overline{Q}$	$R_L = 280 \Omega$ , $C_L = 15 \text{ pF}$		4	6	ns
$t_{PHL}$	$\overline{PRE}$ or $\overline{CLR}$ (CLK high)	$\overline{Q}$ or Q		9	13.5		ns
	$\overline{PRE}$ or $\overline{CLR}$ (CLK low)			5	8		ns
$t_{PLH}$	CLK	Q or $\overline{Q}$		6	9		ns
$t_{PHL}$				6	9		ns

NOTE 3: Load circuits and voltage waveforms are shown in Section 1.

TEXAS  
INSTRUMENTS

POST OFFICE BOX 655012 • DALLAS, TEXAS 75265

## IMPORTANT NOTICE

Texas Instruments (TI) reserves the right to make changes to its products or to discontinue any semiconductor product or service without notice, and advises its customers to obtain the latest version of relevant information to verify, before placing orders, that the information being relied on is current.

TI warrants performance of its semiconductor products and related software to the specifications applicable at the time of sale in accordance with TI's standard warranty. Testing and other quality control techniques are utilized to the extent TI deems necessary to support this warranty. Specific testing of all parameters of each device is not necessarily performed, except those mandated by government requirements.

Certain applications using semiconductor products may involve potential risks of death, personal injury, or severe property or environmental damage ("Critical Applications").

TI SEMICONDUCTOR PRODUCTS ARE NOT DESIGNED, INTENDED, AUTHORIZED, OR WARRANTED TO BE SUITABLE FOR USE IN LIFE-SUPPORT APPLICATIONS, DEVICES OR SYSTEMS OR OTHER CRITICAL APPLICATIONS.

Inclusion of TI products in such applications is understood to be fully at the risk of the customer. Use of TI products in such applications requires the written approval of an appropriate TI officer. Questions concerning potential risk applications should be directed to TI through a local SC sales office.

In order to minimize risks associated with the customer's applications, adequate design and operating safeguards should be provided by the customer to minimize inherent or procedural hazards.

TI assumes no liability for applications assistance, customer product design, software performance, or infringement of patents or services described herein. Nor does TI warrant or represent that any license, either express or implied, is granted under any patent right, copyright, mask work right, or other intellectual property right of TI covering or relating to any combination, machine, or process in which such semiconductor products or services might be or are used.

## **IMPORTANT NOTICE**

Texas Instruments (TI) reserves the right to make changes to its products or to discontinue any semiconductor product or service without notice, and advises its customers to obtain the latest version of relevant information to verify, before placing orders, that the information being relied on is current.

TI warrants performance of its semiconductor products and related software to the specifications applicable at the time of sale in accordance with TI's standard warranty. Testing and other quality control techniques are utilized to the extent TI deems necessary to support this warranty. Specific testing of all parameters of each device is not necessarily performed, except those mandated by government requirements.

Certain applications using semiconductor products may involve potential risks of death, personal injury, or severe property or environmental damage ("Critical Applications").

**TI SEMICONDUCTOR PRODUCTS ARE NOT DESIGNED, INTENDED, AUTHORIZED, OR WARRANTED TO BE SUITABLE FOR USE IN LIFE-SUPPORT APPLICATIONS, DEVICES OR SYSTEMS OR OTHER CRITICAL APPLICATIONS.**

Inclusion of TI products in such applications is understood to be fully at the risk of the customer. Use of TI products in such applications requires the written approval of an appropriate TI officer. Questions concerning potential risk applications should be directed to TI through a local SC sales office.

In order to minimize risks associated with the customer's applications, adequate design and operating safeguards should be provided by the customer to minimize inherent or procedural hazards.

TI assumes no liability for applications assistance, customer product design, software performance, or infringement of patents or services described herein. Nor does TI warrant or represent that any license, either express or implied, is granted under any patent right, copyright, mask work right, or other intellectual property right of TI covering or relating to any combination, machine, or process in which such semiconductor products or services might be or are used.