



Z86233/243

CMOS Z8® 8K ROM CONSUMER CONTROLLER PROCESSOR

FEATURES

Part	ROM Kbytes	RAM Kbytes	I/O	Package Information
Z86233	8	236	24	28-pin DIP
Z86243	8	236	32	40-pin DIP, 44-pin PLCC, 44-pin QFP

- 3.0-to 5.5-Volt Operating Range
- Low-Power Consumption: 40 mW (Typical @5.0V)
- 0°C to +70°C Temperature Range
(-40°C to +105°C Temperature Range Available)
- Three Expanded Register File Control Registers
- Z86C33/C43 Pin and Package Compatible Version
(With Addition of 4K ROM)

- 32 Input/Output Lines (Three with Comparator Inputs)
(Z86243 Only)
- Vectored, Prioritized Interrupts with Programmable
Polarity
- Two Comparators
- Two Programmable 8-Bit Counter/Timers, Each
with a 6-Bit Programmable Prescaler
- Watch-Dog Timer (WDT)/Power-On Reset (POR)
- On-Chip Oscillator that Accepts a Crystal, Ceramic
Resonator, LC, RC, or External Clock Drive
- RAM and ROM Protect

GENERAL DESCRIPTION

The Z86233/243 Consumer Controller Processor is a member of Zilog's Z8® single-chip microcontroller family featuring enhanced wake-up circuitry, programmable Watch-Dog timers and low-EMI options. The parts provide flexible and efficient growth paths for designers currently using the 4K ROM versions of the consumer controller devices (Z86C30/C40/C33/C43).

Four address spaces, the Program Memory, Register File, Data Memory and Expanded Register File (ERF), support a wide range of memory configurations. Through the ERF, the designer has access to two additional control registers which provide extra peripheral devices, I/O ports, and register addresses.

For applications demanding powerful I/O capabilities, the Z86243 provides 32 pins dedicated to input and output. The Z86233 provides 24 pins dedicated to input and output. These lines are grouped into four ports with eight lines each, and are configurable under software control to provide timing, status signals, or parallel I/O.

With ROM/ROMless selectivity, the Z86243 provides both external memory and pre-programmed ROM, which enables this Z8 microcontroller to be used in high-volume applications, or where code flexibility is required.

Note: All Signals with a preceding front slash, "/", are active Low, e.g., /B/W (WORD is active Low); /B/W (BYTE is active Low, only).

Power connections follow conventional descriptions below:

Connection	Circuit	Device
Power Ground	V _{CC} GND	V _{DD} V _{SS}

GENERAL DESCRIPTION (Continued)

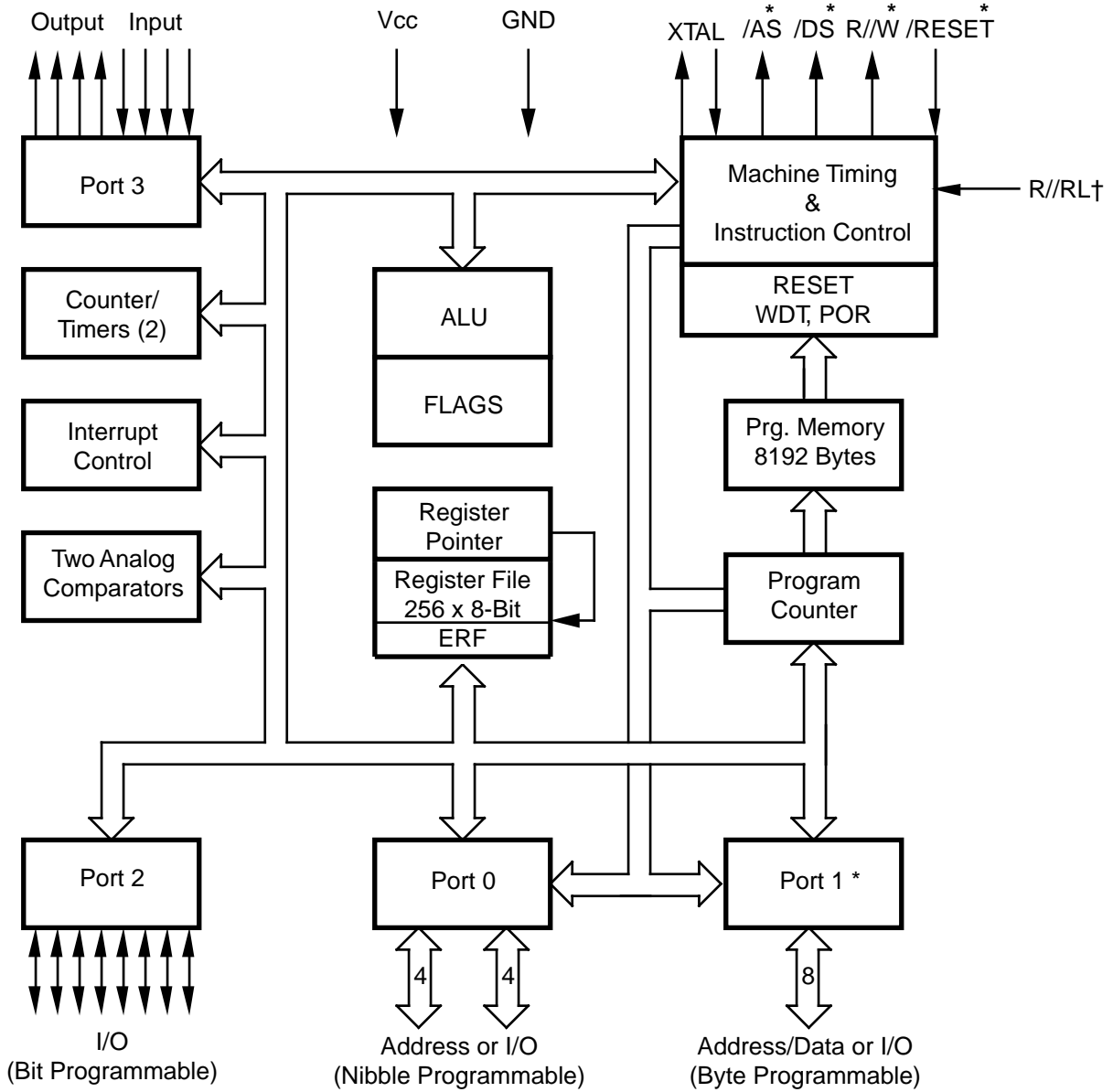

* Not available on Z86233.
† Available on Z86243 44-Pin QFP and PLCC versions only.

Functional Block Diagram

PIN DESCRIPTION

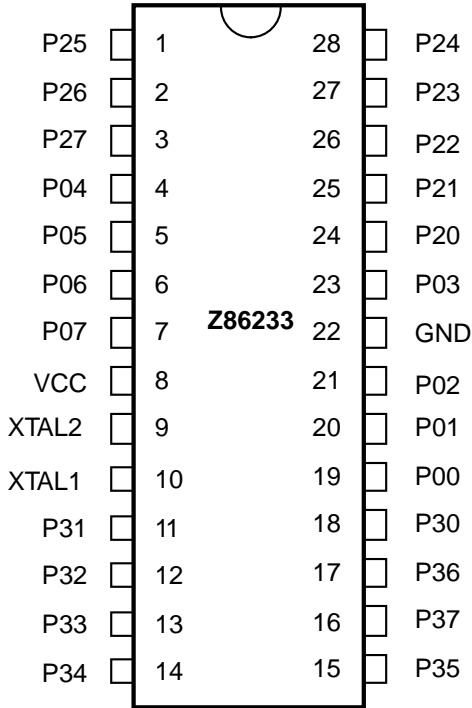

28-Pin DIP Pin Configuration

28-Pin DIP* Pin Identification

Pin #	Symbol	Function	Direction
1-3	P25-P27	Port 2, Pins 5,6,7	In/Output
4-7	P04-P07	Port 0, Pins 4,5,6,7	In/Output
8	V _{CC}	Power Supply	
9	XTAL2	Crystal Oscillator	Output
10	XTAL1	Crystal Oscillator	Input
11-13	P31-P33	Port 3, Pins 1,2,3	Fixed Input
14-15	P34-P35	Port 3, Pins 4,5	Fixed Output
16	P37	Port 3, Pin 7	Fixed Output
17	P36	Port 3, Pin 6	Fixed Output
18	P30	Port 3, Pin 0	Fixed Input
19-21	P00-P02	Port 0, Pins 0,1,2	In/Output
22	GND	Ground	
23	P03	Port 0, Pins 3	In/Output
24-28	P20-P24	Port 2, Pins 0,1,2,3,4	In/Output

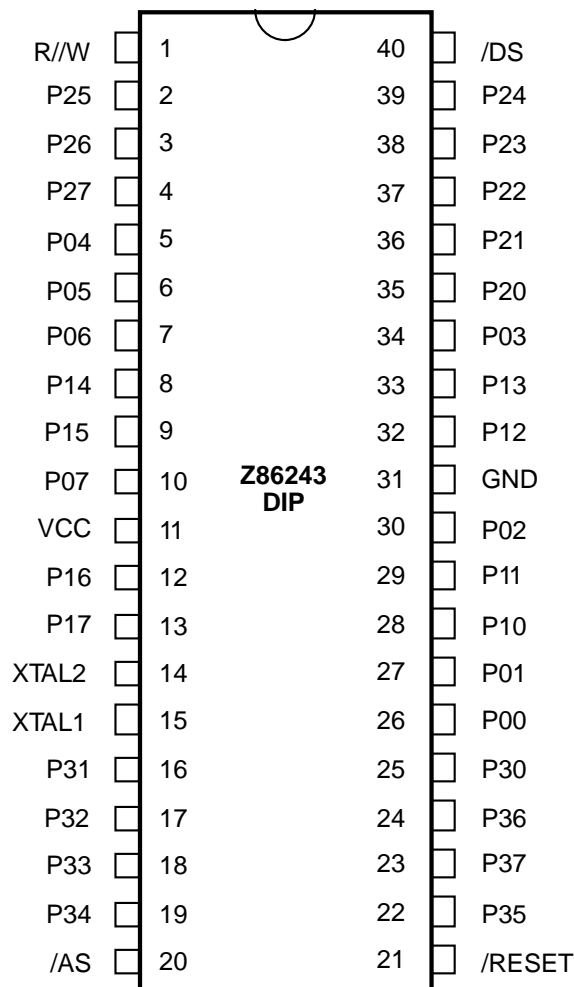
PIN DESCRIPTION (Continued)

40-Pin DIP Pin Configuration
40-Pin DIP Pin Configuration

Pin #	Symbol	Function	Direction
1	R/W	Read/Write	Output
2-4	P25-P27	Port 2, Pins 5, 6, 7	In/Output
5-7	P04-P06	Port 0, Pins 4, 5, 6	In/Output
8-9	P14-P15	Port 1, Pins 4, 5	In/Output
10	P07	Port 0, Pin 7	In/Output
11	V _{CC}	Power Supply	
12-13	P16-P17	Port 1, Pins 6, 7	In/Output
14	XTAL2	Crystal Oscillator	Output
15	XTAL1	Crystal Oscillator	Input
16-18	P31-P33	Port 3, Pins 1, 2, 3	Input
19	P34	Port 3, Pin 4	Output
20	/AS	Address Strobe	Output
21	/RESET	Reset	Input

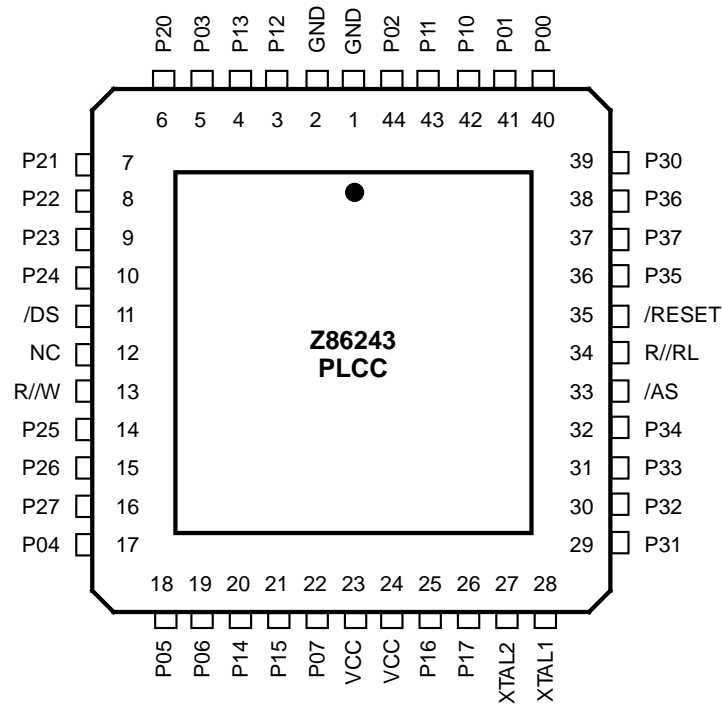
Pin #	Symbol	Function	Direction
22	P35	Port 3, Pin 5	Output
23	P37	Port 3, Pin 7	Output
24	P36	Port 3, Pin 6	Output
25	P30	Port 3, Pin 0	Input
26-27	P00-P01	Port 0, Pins 0,1	In/Output
28-29	P10-P11	Port 1, Pins 0,1	In/Output
30	P02	Port 0, Pin 2	In/Output
31	GND	Ground	
32-33	P12-P13	Port 1, Pins 2, 3	In/Output
34	P03	Port 0, Pin 3	In/Output
35-39	P20-P24	Port 2, Pins 0,1,2,3,4	In/Output
40	/DS	Data Strobe	Output



44-Pin PLCC Pin Configuration

44-Pin PLCC Pin Identification

Pin #	Symbol	Function	Direction	Pin #	Symbol	Function	Direction
1	GND	Ground		27	XTAL2	Crystal Oscillator	Output
2	GND	Ground		28	XTAL1	Crystal Oscillator	Input
3-4	P12-P13	Port 1, Pins 2,3	In/Output	29-31	P31-P33	Port 3, Pins 1,2,3	Input
5	P03	Port 0, Pin 3	In/Output	32	P34	Port 3, Pin 4	Output
6-10	P20-P24	Port 2, Pins 0,1,2,3,4	In/Output	33	/AS	Address Strobe	Output
11	/DS	Data Strobe	Output	34	R//RL	ROM/ROMless select	Input
12	N/C	Not Connected		35	/RESET	Reset	Input
13	R//W	Read/Write	Output	36	P35	Port 3, Pin 5	Output
14-16	P25-P27	Port 2, Pins 5,6,7	In/Output	37	P37	Port 3, Pin 7	Output
17-19	P04-P06	Port 0, Pins 4,5,6	In/Output	38	P36	Port 3, Pin 6	Output
20-21	P14-P15	Port 1, Pins 4,5	In/Output	39	P30	Port 3, Pin 0	Input
22	P07	Port 0, Pin 7	In/Output	40-41	P00-P01	Port 0, Pins 0,1	In/Output
23	V _{CC}	Power Supply		42-43	P10-P11	Port 1, Pins 0,1	In/Output
24	V _{CC}	Power Supply		44	P02	Port 0, Pin 2	In/Output
25-26	P16-P17	Port 1, Pins 6,7	In/Output				

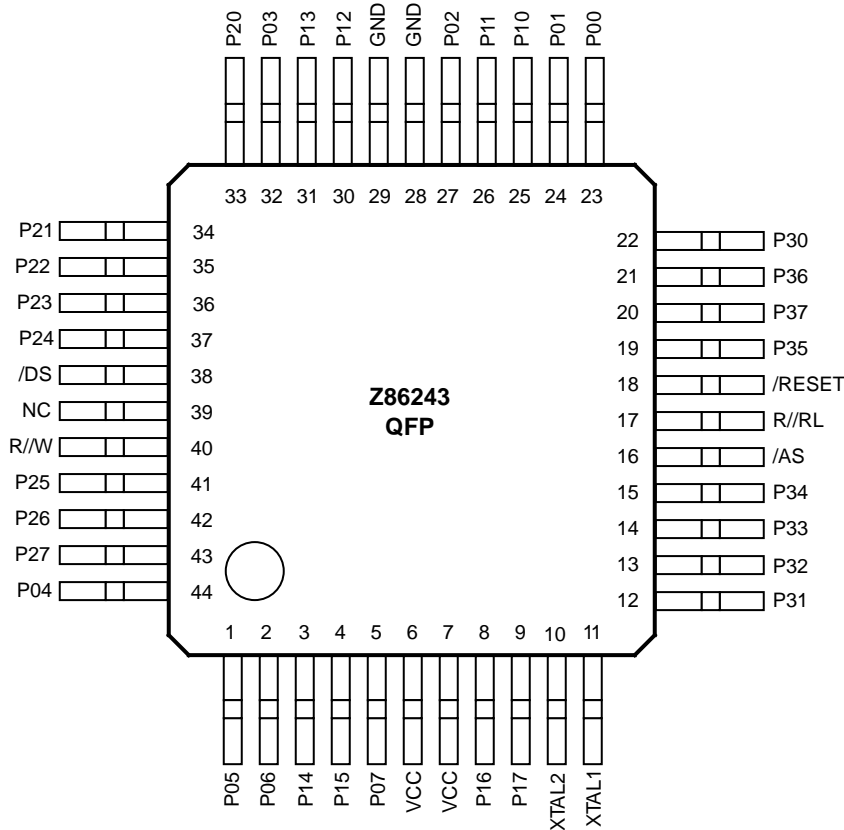
PIN DESCRIPTION (Continued)

44-Pin QFP Pin Configuration
44-Pin QFP Pin Identification

Pin #	Symbol	Function	Direction	Pin #	Symbol	Function	Direction
1-2	P05-P06	Port 0, Pins 5,6	In/Output	21	P36	Port 3, Pin 6	Output
3-4	P14-P05	Port 1, Pins 4,5	In/Output	22	P30	Port 3, Pin 0	Input
5	P07	Port 0, Pin 7	In/Output	23-24	P00-P01	Port 0, Pin 0,1	In/Output
6-7	V _{CC}	Power Supply		25-26	P10-P11	Port 1, Pins 0,1	In/Output
8-9	P16-P17	Port 1, Pins 6,7	In/Output	27	P02	Port 0, Pin 2	In/Output
10	XTAL2	Crystal Oscillator	Output	28	GND	Ground	
11	XTAL1	Crystal Oscillator	Input	29	GND	Ground	
12-14	P31-P33	Port 3, Pins 1,2,3	Input	30-31	P12-P13	Port 1, Pins 2,3	In/Output
15	P34	Port 3, Pin 4	Output	32	P03	Port 0, Pin 3	In/Output
16	/AS	Address Strobe	Output	33-37	P20-24	Port 2, Pins 0,1,2,3,4	In/Output
17	R//RL	ROM/ROMless select	Input	38	/DS	Data Strobe	Output
18	/RESET	Reset	Input	39	N/C	Not Connected	
19	P35	Port 3, Pin 5	Output	40	R//W	Read/Write	Output
20	P37	Port 3, Pin 7	Output	41-43	P25-P27	Port 2, Pins 5,6,7	In/Output
				44	P04	Port 0, Pin 4	In/Output

ABSOLUTE MAXIMUM RATINGS

Parameter	Min	Max	Units
Ambient Temperature under Bias	-40	+105	C
Storage Temperature	-65	+150	C
Voltage on any Pin with Respect to V_{SS} [Note 1]	-0.6	+7	V
Voltage on V_{DD} Pin with Respect to V_{SS}	-0.3	+7	V
Voltage on XTAL1 and /RESET Pins with Respect to V_{SS} [Note 2]	-0.6	$V_{DD} + 1$	V
Total Power Dissipation		770	mW
Maximum Current out of V_{SS}		140	mA
Maximum Current into V_{DD}		125	mA
Maximum Current into an Input Pin [Note 3]	-600	+600	μ A
Maximum Current into an Open-Drain Pin [Note 4]	-600	+600	μ A
Maximum Output Current Sunked by Any I/O Pin		25	mA
Maximum Output Current Sourced by Any I/O Pin		25	mA

Notes:

- [1] This applies to all pins except XTAL pins and where otherwise noted.
 [2] There is no input protection diode from pin to V_{DD} .
 [3] This excludes XTAL pins.
 [4] Device pin is not at an output Low state.

Notice:

Stresses greater than those listed under Absolute Maximum Ratings may cause permanent damage to the device. This is a stress rating only; functional operation of the device at any condition above those indicated in the operational sections of these specifications is not implied. Exposure to absolute maximum rating conditions for an extended period may affect device reliability.

Total power dissipation should not exceed 770 mW for the package. Power dissipation is calculated as follows:

$$\text{Total Power Dissipation} = V_{DD} \times [I_{DD} - (\text{sum of } I_{OH})] \\ + \text{sum of } [(V_{DD} - V_{OH}) \times I_{OH}] \\ + \text{sum of } (V_{OL} \times I_{OL})$$

STANDARD TEST CONDITIONS

The characteristics listed below apply for standard test conditions as noted. All voltages are referenced to Ground. Positive current flows into the referenced pin (Test Load).

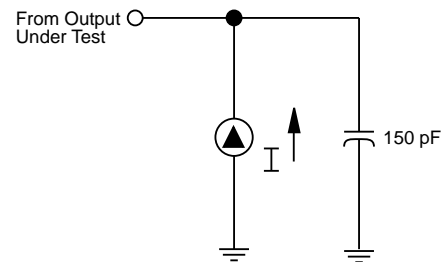

Test Load Diagram

CAPACITANCE

$T_A = 25^\circ\text{C}$, $V_{CC} = \text{GND} = 0\text{V}$, $f = 1.0\text{ MHz}$; unmeasured pins returned to GND.

Parameter	Min	Max
Input capacitance	0	12 pF
Output capacitance	0	12 pF
I/O capacitance	0	12 pF

DC ELECTRICAL CHARACTERISTICS

Sym	Parameter	V _{CC} Note [3]	T _A = 0° C to +70°C		T _A = -40°C to +105°C		Typical [13] @ 25°C	Units	Conditions	Notes
			Min	Max	Min	Max				
V _{CH}	Clock Input High Voltage	3.0V	0.7 V _{CC}	V _{CC} +0.3	0.7 V _{CC}	V _{CC} +0.3	1.3	V	Driven by External Clock Generator	
		5.5V	0.7 V _{CC}	V _{CC} +0.3	0.7 V _{CC}	V _{CC} +0.3	2.5	V	Driven by External Clock Generator	
V _{CL}	Clock Input Low Voltage	3.0V	GND-0.3	0.2 V _{CC}	GND-0.3	0.2 V _{CC}	0.7	V	Driven by External Clock Generator	
		5.5V	GND-0.3	0.2 V _{CC}	GND-0.3	0.2 V _{CC}	1.5	V	Driven by External Clock Generator	
V _{IH}	Input High Voltage	3.0V	0.7 V _{CC}	V _{CC} +0.3	0.7 V _{CC}	V _{CC} +0.3	1.3	V		
		5.5V	0.7 V _{CC}	V _{CC} +0.3	0.7 V _{CC}	V _{CC} +0.3	2.5	V		
V _{IL}	Input Low Voltage	3.0V	GND-0.3	0.2 V _{CC}	GND-0.3	0.2 V _{CC}	0.7	V		
		5.5V	GND-0.3	0.2 V _{CC}	GND-0.3	0.2 V _{CC}	1.5	V		
V _{OH1}	Output High Voltage	3.0V	V _{CC} -0.4		V _{CC} -0.4		3.1	V	I _{OH} = -2.0 mA	[8]
		5.5V	V _{CC} -0.4		V _{CC} -0.4		4.8	V	I _{OH} = -2.0 mA	[8]
V _{OL1}	Output Low Voltage	3.0V		0.6		0.6	0.2	V	I _{OL} = +4.0 mA	[8]
		5.5V		0.4		0.4	0.1	V	I _{OL} = +4.0 mA	[8]
V _{OL2}	Output Low Voltage	3.0V		1.2		1.2	0.3	V	I _{OL} = +6 mA	[8]
		5.5V		1.2		1.2	0.3	V	I _{OL} = +12 mA	[8]
V _{RH}	Reset Input High Voltage	3.0V	.8 V _{CC}	V _{CC}	.8 V _{CC}	V _{CC}	1.5	V		
		5.5V	.8 V _{CC}	V _{CC}	.8 V _{CC}	V _{CC}	2.1	V		
V _{RI}	Reset Input Low Voltage	3.0V	GND-0.3	0.2 V _{CC}	GND-0.3	0.2 V _{CC}	1.1	V		
		5.5V	GND-0.3	0.2 V _{CC}	GND-0.3	0.2 V _{CC}	1.7	V		
V _{OFFSET}	Comparator Input Offset Voltage	3.0V		25		25	10	mV		[10]
		5.5V		25		25	10	mV		[10]
I _{IL}	Input Leakage	3.0V	-1	1	-1	2	<1	μA	V _{IN} = 0V, V _{CC}	
		5.5V	-1	1	-1	2	<1	μA	V _{IN} = 0V, V _{CC}	
I _{OL}	Output Leakage	3.0V	-1	1	-1	2	<1	μA	V _{IN} = 0V, V _{CC}	
		5.5V	-1	1	-1	2	<1	μA	V _{IN} = 0V, V _{CC}	
I _{IR}	Reset Input Current	3.0V		-130		-130	-25	μA		
		5.5V		-180		-180	-40	μA		
I _{CC}	Supply Current	3.0V		20		20	7	mA	@ 16 MHz	[4]
		5.5V		25		25	20	mA	@ 16 MHz	[4]
		3.0V		15		15	5	mA	@ 12 MHz	[4]
		5.5V		20		20	15	mA	@ 12 MHz	[4]
I _{CC1}	Standby Current	3.0V		4.5		4.5	2.0	mA	HALT Mode V _{IN} = 0V, V _{CC} @ 16 MHz	[4]
		5.5V		8		8	3.7	mA	HALT Mode V _{IN} = 0V, V _{CC} @ 16 MHz	[4]
		3.0V		3.4		3.4	1.5	mA	Clock Divide-by-16 @ 16 MHz	[4]
		5.5V		7.0		7.0	2.9	mA	Clock Divide-by-16 @ 16 MHz	[4]
I _{CC2}	Standby Current	3.0V		8		15	1	μA	STOP Mode V _{IN} = 0V, V _{CC} WDT is not Running	[6,11]
		5.5V		10		20	2	μA	STOP Mode V _{IN} = 0V, V _{CC} WDT is not Running	[6,11]
		3.0V		500		600	310	μA	STOP Mode V _{IN} = 0V, V _{CC} WDT is Running	[6,11,14]
		5.5V		800		1000	600	μA	STOP Mode V _{IN} = 0V, V _{CC} WDT is Running	[6,11,14]

DC ELECTRICAL CHARACTERISTICS (Continued)

Sym	Parameter	V _{CC} Note [3]	T _A = 0° C to +70°C		T _A = -40°C to +105°C		Typical [13] @ 25°C	Units	Conditions	Notes
			Min	Max	Min	Max				
V ^{ICR}	Input Common Mode Voltage Range	3.0	0	V _{CC} -1.0V	0	V _{CC} -1.5V		V		[10]
		5.5	0	V _{CC} -1.0V	0	V _{CC} -1.5V		V		[10]
I _{ALL}	Auto Latch Low Current	3.0V		8		10	5	μA	0V < V _{IN} < V _{CC}	[9]
		5.5V		15		20	11	μA	0V < V _{IN} < V _{CC}	[9]
I _{ALH}	Auto Latch High Current	3.0V		-5		-7	-3	μA	0V < V _{IN} < V _{CC}	[9]
		5.5V		-8		-10	-6	μA	0V < V _{IN} < V _{CC}	[9]
V _{LV}	V _{CC} Low Voltage Protection Voltage		2.0	2.8	2.2	3.0	2.5	V	2 MHz max Int. CLK Freq.	[7]
V _{OH}	Output High Voltage (Low EMI Mode)	3.3V	V _{CC} -0.4		V _{CC} -0.4		3.1	V	I _{OH} = -0.5 mA	
		5.0V	V _{CC} -0.4		V _{CC} -0.4		4.8	V	I _{OH} = -0.5 mA	
V _{OL}	Output Low Voltage (Low EMI Mode)	3.3V		0.6		0.6	0.2	V	I _{OL} = 1.0 mA	
		5.0V		0.4		0.4	0.1	V	I _{OL} = 1.0 mA	

Notes:

- [1] I_{CC1} Typ Max Unit Freq
 Clock-Driven 0.3 mA 5 mA 8 MHz
 Resonator or Crystal 3.0 mA 5 mA 8 MHz [5]
- [2] GND = 0V.
- [3] The V_{DD} voltage specification of 3.0V guarantees 3.3V ±0.3V, and the V_{DD} voltage specification of 5.5V guarantees 5.0V ±0.5V.
- [4] All outputs unloaded, I/O pins floating, inputs at rail.
- [5] CL1 = CL2 = 100 pF.
- [6] Same as note [4] except inputs at V_{CC}.
- [7] The V_{LV} increases as the temperature decreases.
- [8] Standard Mode (not Low EMI).
- [9] Auto Latch (Mask Option) selected.
- [10] For analog comparator, inputs when analog comparators are enabled.
- [11] Clock must be forced Low, when XTAL 1 is clock-driven and XTAL2 is floating.
- [12] Excludes clock pins.
- [13] Typicals are at V_{CC} = 5.0V and 3.3V.
- [14] Internal RC selected.

AC CHARACTERISTICS

External I/O or Memory Read and Write Timing Diagram

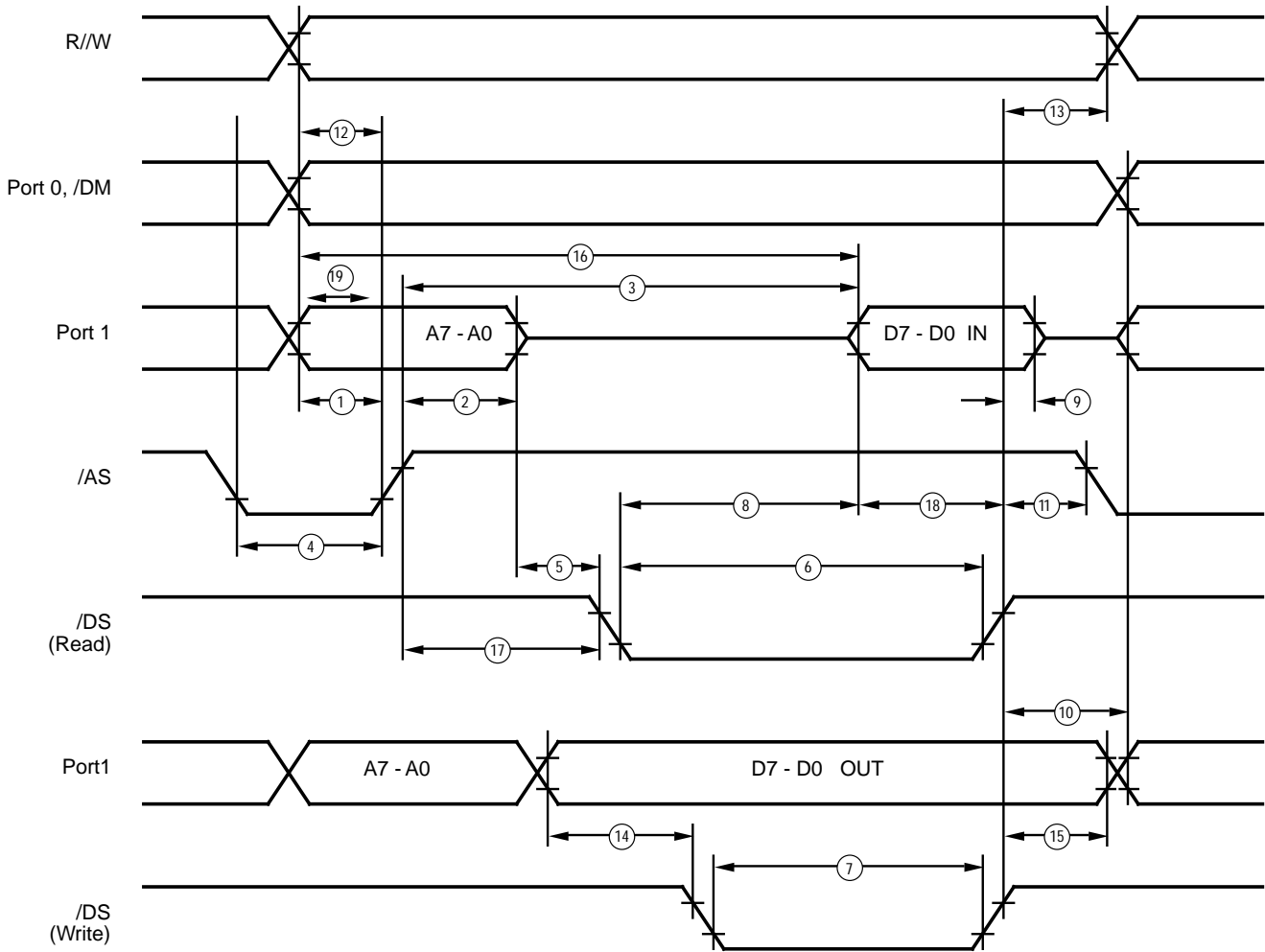

External I/O or Memory Read/Write Timing

AC CHARACTERISTICS

External I/O or Memory Read and Write Timing Table
 (SCLK/TCLK = XTAL/2)

No	Symbol	Parameter	Note [3] V _{cc}	T _A = 0°C to +70°C				T _A = -40°C to +105°C				Units	Notes
				12 MHz		16 MHz		12 MHz		16 MHz			
				Min	Max	Min	Max	Min	Max	Min	Max		
1	TdA(AS)	Address Valid to /AS Rise Delay	3.0	35		25		35		25		ns	[2]
			5.5	35		25		35		25			
2	TdAS(A)	/AS Rise to Address Float Delay	3.0	45		35		45		35		ns	[2]
			5.5	45		35		45		35		ns	
3	TdAS(DR)	/AS Rise to Read Data Req'd Valid	3.0		250		180		250		180	ns	[1,2]
			5.5		250		180		250		180	ns	
4	TwAS	/AS Low Width	3.0	55		40		55		40		ns	[2]
			5.5	55		40		55		40		ns	
5	Td	Address Float to /DS Fall	3.0	0		0		0		0		ns	
			5.5	0		0		0		0		ns	
6	TwDSR	/DS (Read) Low Width	3.0	200		135		200		135		ns	[1,2]
			5.5	200		135		200		135		ns	
7	TwDSW	/DS (Write) Low Width	3.0	110		80		110		80		ns	[1,2]
			5.5	110		80		110		80		ns	
8	TdDSR(DR)	/DS Fall to Read Data Req'd Valid	3.0		150		75		150		75	ns	[1,2]
			5.5		150		75		150		75	ns	
9	ThDR(DS)	Read Data to /DS Rise Hold Time	3.0	0		0		0		0		ns	[2]
			5.5	0		0		0		0		ns	
10	TdDS(A)	/DS Rise to Address Active Delay	3.0	45		50		45		50		ns	[2]
			5.5	55		50		55		50		ns	
11	TdDS(AS)	/DS Rise to /AS Fall Delay	3.0	30		35		30		35		ns	[2]
			5.5	45		35		45		55		ns	
12	TdR/W(AS)	R/W Valid to /AS Rise Delay	3.0	45		25		45		25		ns	[2]
			5.5	45		25		45		25		ns	
13	TdDS(R/W)	/DS Rise to R/W Not Valid	3.0	45		35		45		35		ns	[2]
			5.5	45		35		45		35		ns	
14	TdDW(DSW)	Write Data Valid to /DS Fall (Write) Delay	3.0	55		25		55		25		ns	[2]
			5.5	55		25		55		25		ns	
15	TdDS(DW)	/DS Rise to Write Data Not Valid Delay	3.0	45		35		45		35		ns	[2]
			5.5	55		35		55		35		ns	
16	TdA(DR)	Address Valid to Read Data Req'd Valid	3.0		310		230		310		230	ns	[1,2]
			5.5		310		230		310		230	ns	
17	TdAS(DS)	/AS Rise to /DS Fall Delay	3.0	65		45		65		45		ns	[2]
			5.5	65		45		65		45		ns	
18	TdDI(DS)	Data Input Setup to /DS Rise	3.0	115		60		115		60		ns	[1,2]
			5.5	75		60		75		60		ns	
19	TdDM(AS)	/DM Valid to /AS Rise Delay	3.0	35		30		35		30		ns	[2]
			5.5	35		30		35		30		ns	

Notes:

- [1] When using extended memory timing add 2 TpC.
- [2] Timing numbers given are for minimum TpC.
- [3] The V_{DD} voltage specification of 3.0V guarantees 3.3V ±0.3V, and the V_{DD} voltage specification of 5.5V guarantees 5.0V ±0.5V.

Standard Test Load

All timing references use 0.7 V_{cc} for a logic 1 and 0.2 V_{cc} for a logic 0.

AC ELECTRICAL CHARACTERISTICS

Additional Timing Diagram

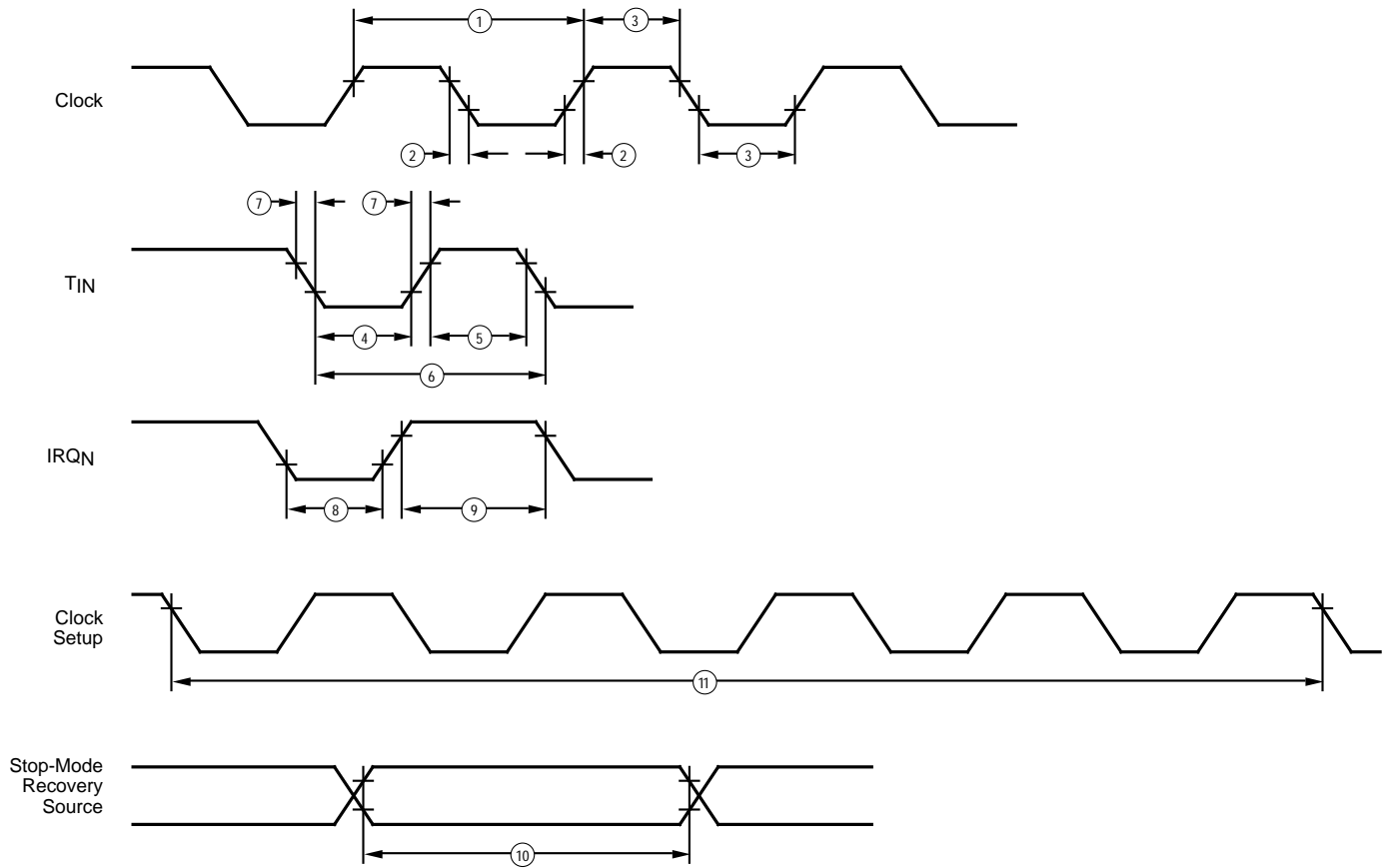

Additional Timing

AC ELECTRICAL CHARACTERISTICS

Additional Timing Table (SCLK/TCLK = XTAL/2)

No	Symbol	Parameter	V _{CC} Note[6]	T _A = 0°C to +70°C				T _A = -40°C to +105°C				Units	Notes
				12 MHz		16 MHz		12 MHz		16 MHz			
				Min	Max	Min	Max	Min	Max	Min	Max		
1	TpC	Input Clock Period	3.0V	83	DC	62.5	DC	83	DC	62.5	DC	ns	[1]
			5.5V	83	DC	62.5	DC	83	DC	62.5	DC	ns	[1]
2	TrC,TfC	Clock Input Rise & Fall Times	3.0V		15		15		15		15	ns	[1]
			5.5V		15		15		15		15	ns	[1]
3	TwC	Input Clock Width	3.0V	41		31		41		31		ns	[1]
			5.5V	41		31		41		31		ns	[1]
4	TwTinL	Timer Input Low Width	3.0V	100		100		100		100		ns	[1]
			5.5V	70		70		70		70		ns	[1]
5	TwTinH	Timer Input High Width	3.0V	5TpC		5TpC		5TpC		5TpC			[1]
			5.5V	5TpC		5TpC		5TpC		5TpC			[1]
6	TpTin	Timer Input Period	3.0V	8TpC		8TpC		8TpC		8TpC			[1]
			5.5V	8TpC		8TpC		8TpC		8TpC			[1]
7	TrTin, TfTin	Timer Input Rise & Fall Timer	3.0V		100		100		100		100	ns	[1]
			5.5V		100		100		100		100	ns	[1]
8A	TwIL	Int. Request Low Time	3.0V	100		100		100		100		ns	[1,2]
			5.5V	70		70		70		70		ns	[1,2]
8B	TwIL	Int. Request Low Time	3.0V	5TpC		5TpC		5TpC		5TpC			[1,3]
			5.5V	5TpC		5TpC		5TpC		5TpC			[1,3]
9	TwIH	Int. Request Input High Time	3.0V	5TpC		5TpC		5TpC		5TpC			[1,2]
			5.5V	5TpC		5TpC		5TpC		5TpC			[1,2]
10	TwsM	STOP-Mode Recovery Width Spec	3.0V	12		12		12		12		ns	
			5.5V	12		12		12		12		ns	
11	Tost	Oscillator Startup Time	3.0V		5TpC		5TpC		5TpC		5TpC		[4]
			5.5V		5TpC		5TpC		5TpC		5TpC		[4]
12	Twdt	Watch-Dog Timer Delay Time	3.0V	10		10		10		10		ms	D1 0 0 [5]
			5.5V	5		5		5		5		ms	0 0 [5]
			3.0V	20		20		20		20		ms	0 1 [5]
			5.5V	10		10		10		10		ms	0 1 [5]
			3.0V	40		40		40		40		ms	1 0 [5]
			5.5V	20		20		20		20		ms	1 0 [5]
			3.0V	160		160		160		160		ms	1 1 [5]
			5.5V	80		80		80		80		ms	1 1 [5]
13	T _{POR}	Power On Reset Delay	3.0V	7	24	7	24	7	25	7	25	ms	
			5.5V	3	13	3	13	3	14	3	14	ms	

Notes:

- [1] Timing Reference uses 0.7 V_{CC} for a logic 1 and 0.2 V_{CC} for a logic 0.
- [2] Interrupt request via Port 3 (P31-P33).
- [3] Interrupt request via Port 3 (P30).
- [4] SMR-D5 = 0.
- [5] Reg. WDTMR, internal RC used.
- [6] The V_{DD} voltage specification of 3.0V guarantees 3.3V ±0.3V, and the V_{DD} voltage specification of 5.5V guarantees 5.0V ±0.5V.

AC ELECTRICAL CHARACTERISTICS

Additional Timing Table (Divide-By-One Mode, SCLK/TCLK = XTAL)

No	Symbol	Parameter	V _{cc} Note [6]	T _A = 0°C to +70°C		T _A = -40°C to +105°C		Units	Notes
				4 MHz		4 MHz			
				Min	Max	Min	Max		
1	TpC	Input Clock Period	3.0V	250	DC	250	DC	ns	[1,7,8]
			5.5V	250	DC	250	DC	ns	[1,7,8]
2	TrC,TfC	Clock Input Rise & Fall Times	3.0V		25		25	ns	[1,7,8]
			5.5V		25		25	ns	[1,7,8]
3	TwC	Input Clock Width	3.0V	125		125		ns	[1,7,8]
			5.5V	125		125		ns	[1,7,8]
4	TwTinL	Timer Input Low Width	3.0V	100		100		ns	[1,7,8]
			5.5V	70		70		ns	[1,7,8]
5	TwTinH	Timer Input High Width	3.0V	3TpC		3TpC			[1,7,8]
			5.5V	3TpC		3TpC			[1,7,8]
6	TpTin	Timer Input Period	3.0V	4TpC		4TpC			[1,7,8]
			5.5V	4TpC		4TpC			[1,7,8]
7	TrTin, TfTin	Timer Input Rise & Fall Timer	3.0V		100		100	ns	[1,7,8]
			5.5V		100		100	ns	[1,7,8]
8A	TwlL	Int. Request Low Time	3.0V	100		100		ns	[1,2,7,8]
			5.5V	70		70		ns	[1,2,7,8]
8B	TwlL	Int. Request Low Time	3.0V	3TpC		3TpC			[1,3,7,8]
			5.5V	3TpC		3TpC			[1,3,7,8]
9	TwhH	Int. Request Input High Time	3.0V	3TpC		3TpC			[1,2,7,8]
			5.5V	3TpC		2TpC			[1,2,7,8]
10	TwsM	STOP-Mode Recovery Width Spec	3.0V	12		12		ns	[4,8]
			5.5V	12		12		ns	[4,8]
11	Tost	Oscillator Startup Time	3.0V		5TpC		5TpC		[4,8,9]
			5.5V		5TpC		5TpC		[4,8,9]

Notes:

- [1] Timing Reference uses 0.7 V_{cc} for a logic 1 and 0.2 V_{cc} for a logic 0.
- [2] Interrupt request via Port 3 (P33-P31).
- [3] Interrupt request via Port 3 (P30).
- [4] SMR-D5 = 1, POR STOP mode delay is on.
- [5] Reg. WDTMR.
- [6] The V_{DD} voltage specification of 3.0V guarantees 3.3V ±0.3V, and the V_{DD} voltage specification of 5.5V guarantees 5.5V ±0.5V.
- [7] SMR D1 = 0.
- [8] Maximum frequency for internal system clock is 4 MHz when using XTAL divide-by-one mode.
- [9] For RC and LC oscillator, and for oscillator driven by clock driver.

AC ELECTRICAL CHARACTERISTICS

Handshake Timing Diagrams

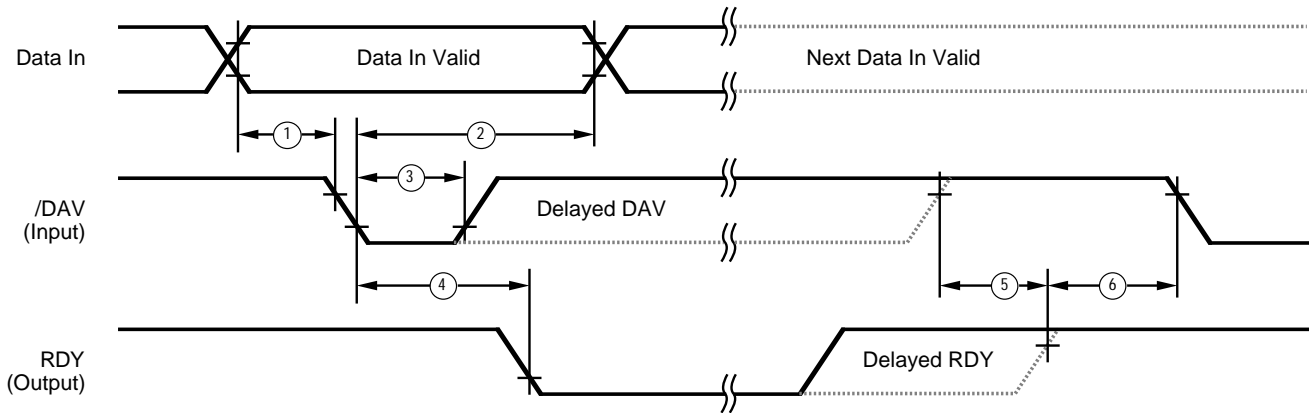

Input Handshake Timing

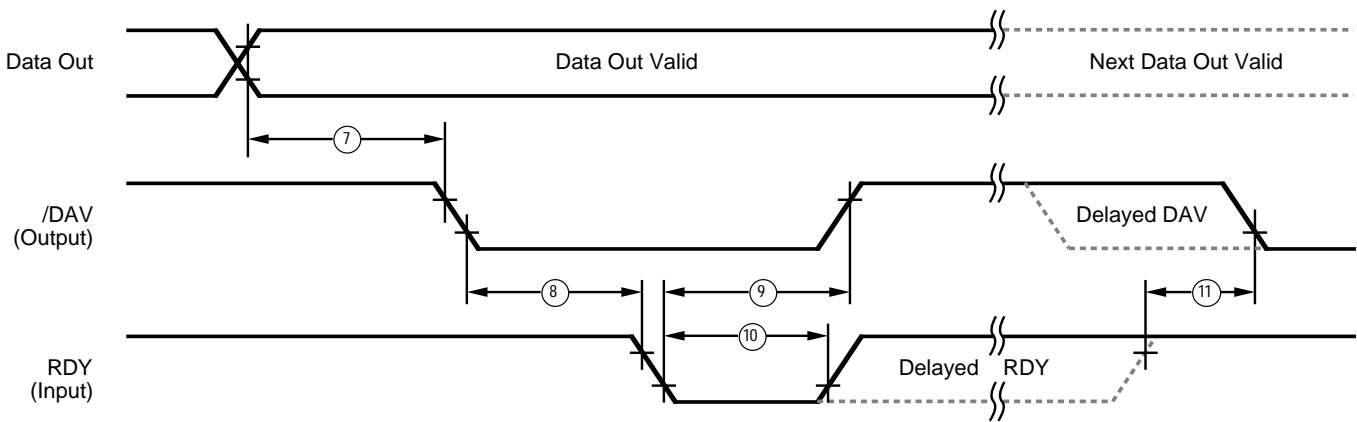

Output Handshake Timing

AC ELECTRICAL CHARACTERISTICS

Handshake Timing Table

No	Symbol	Parameter	V _{CC} Note[1,2]	T _A = 0°C to +70°C				T _A = -40°C to +105°C				Data Direction
				12 MHz		16 MHz		12 MHz		16 MHz		
				Min	Max	Min	Max	Min	Max	Min	Max	
1	TsDI(DAV)	Data In Setup Time	3.0V	0		0		0		0		IN
			5.5V	0		0		0		0		IN
2	ThDI(DAV)	Data In Hold Time	3.0V	160		160		160		160		IN
			5.5V	115		115		115		115		IN
3	TwDAV	Data Available Width	3.0V	155		155		155		155		IN
			5.5V	110		110		110		110		IN
4	TdDAVI(RDY)	DAV Fall to RDY Fall Delay	3.0V		160		160		160		160	IN
			5.5V		115		115		115		115	IN
5	TdDAVI(dRDY)	DAV Rise to RDY Rise Delay	3.0V		120		120		120		120	IN
			5.5V		80		80		80		80	IN
6	TdRDY0(DAV)	RDY Rise to DAV Fall Delay	3.0V	0		0		0		0		IN
			5.5V	0		0		0		0		IN
7	TdD0(DAV)	Data Out to DAV Fall Delay	3.0V	42		31		42		31		OUT
			5.5V	42		31		42		31		OUT
8	TdDAV0(RDY)	DAV Fall to RDY Fall Delay	3.0V	0		0		0		0		OUT
			5.5V	0		0		0		0		OUT
9	TdRDY0(DAV)	RDY Fall to DAV Rise Delay	3.0V		160		160		160		160	OUT
			5.5V		115		115		115		115	OUT
10	TwRDY	RDY Width	3.0V	110		110		110		110		OUT
			5.5V	80		80		80		80		OUT
11	TdRDY0d(DAV)	RDY Rise to DAV Fall Delay	3.0V		110		110		110		110	OUT
			5.5V		80		80		80		80	OUT

Notes:

[1] Timing Reference uses 0.7 V_{CC} for a logic 1 and 0.2 V_{CC} for a logic 0.

[2] The V_{DD} voltage specification of 3.0V guarantees 3.3V ± 0.3V and the V_{DD} voltage specification of 5.5V guarantees 5.0V ± 0.5V.